

THE  
**BARRETO**  
MODEL 912M  
HYDRAULIC TRENCHER  
EXPLODED VIEWS WITH PART NUMBERS

CONGRATULATIONS!

You are now the proud owner of a BARRETO trencher. The following pages have detailed views of your trencher, along with corresponding part numbers. If you have any questions or need any replacement parts in the future, please contact us at your convenience. Our toll-free phone number, fax and email are listed below and parts may be ordered through any of these methods.

Thank you for your patronage and confidence in BARRETO equipment.

Barreto Manufacturing, Inc.  
Innovative Equipment Engineered to Last  
66498 Highway 203  
La Grande, OR 97850  
1-800-525-7348  
1-541-963-6755 Fax  
E-Mail: [info@barretomfg.com](mailto:info@barretomfg.com)  
Web Site: <http://www.barretomfg.com>

Machine Identification Record

BARRETO Customer number \_\_\_\_\_

Machine model number \_\_\_\_\_

Machine serial number \_\_\_\_\_

Engine manufacturer \_\_\_\_\_

Engine model number \_\_\_\_\_

Engine serial number \_\_\_\_\_

UPDATED 8/17/22

TIRE OPTIONS:

00256 R1 AIR TIRES & HUBS KIT (SEE DRAWING)  
 03190-FW AIR TIRE, RIGHT  
 03191-FW AIR TIRE, LEFT

00256 R1-F FOAM FILLED TIRES & HUBS KIT  
 03190-F FOAM FILLED TIRE, RIGHT  
 03191-F FOAM FILLED TIRE, LEFT

03046 WIDE AIR TIRE, RIGHT  
 03047 WIDE AIR TIRE, LEFT

03046-F WIDE FOAM FILLED TIRE, RIGHT  
 03047-F WIDE FOAM FILLED TIRE, LEFT

ITEM NO.	QTY.	PART NO.	DESCRIPTION
1	1	00268	TRANSMISSION ASSEMBLY
2	1	00256 R1	FREE WHEELING HUB & WHEEL, SET RH & LH
3	1	00267	LID ASSEMBLY
4	1	00249	MANIFOLD ASSEMBLY
5	1	10232	BODY 912
6	2	10174	AXLE BEARING HOUSING
7	1	10238	TRANSMISSION BRACE, REAR
8	1	10240	TRANSMISSION BRACET, FRONT
9	1	03014TR	AXLE COUPLER
10	1	10231	AXLE, LEFT
11	4	05606	SNAP RING, 1-1/8" EXTERNAL
12	2	05034	SNAP RING, 1-3/16 EXT. SH-118
13	4	03012	SEAL, AXLE
14	2	03280	BALL BEARING, SKF 6206
15	1	03503	SIGHT GAUGE
16	1	10361	FITTING, 6409-8 PLUG
17	2	05018	KEY, 1/4 X 1/4 X 1-1/4 HARDENED
18	2	05199	KEY, 1/4 X 1/4 X 2-1/2 HARDENED
19	1	03040-57	DECAL, "HYDRAULIC OIL LEVEL"
20	1	04440-08	DECAL: 912 SERIAL NUMBER
21	2	03520	MAGNET
22	6	10623	O-RING, 2-010, 3/8 OD X 1/16 SECTION
23	2	03923	O-RING, 2-142, 2-9/16 OD X 3/32 SECTION
24	2	10602	O-RING, 2-239, 3-7/8 OD X 1/8 SECTION
25	2	05044	GREASE ZERK, 1/4-28 UNF
26	1	03008	THRUST WASHER, 1.136 X 1.784 X .032 HARD
27	8	05140	WHIZ-LOCK 5/16 - 18 X 3/4
28	6	12113	WHIZ-LOCK 1/4 - 20 X 1-1/2 SMOOTH FLANGE

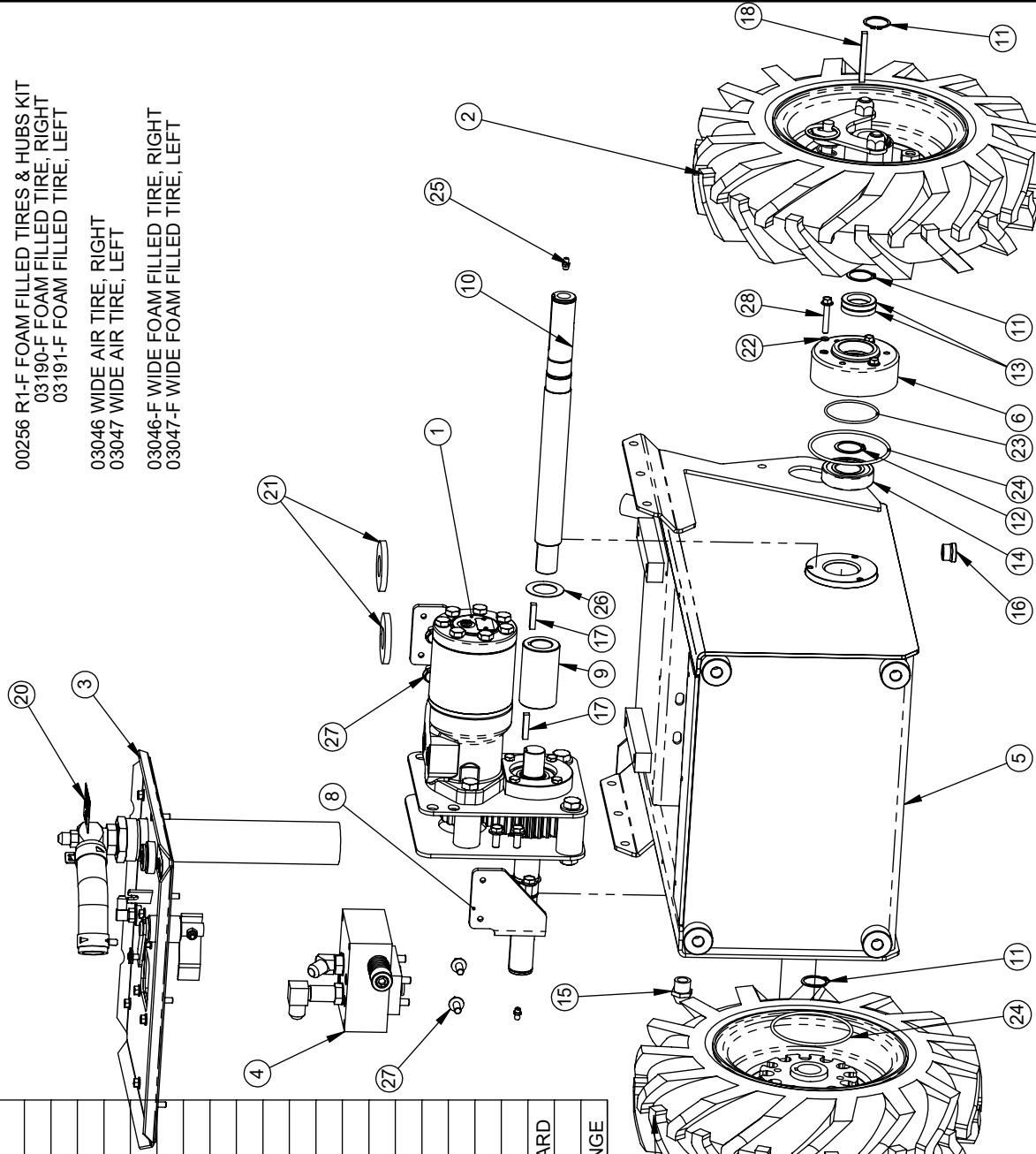

TITLE: BODY ASSEMBLY

PRODUCT LINE: TRENCHER 912

DATE: 3/11/04

SCALE: 1:8

DWG# 00247

SHEET 1 OF 1

# BARRETO

REF	QTY.	PART NO.	DESCRIPTION
1	1	02200	MANIFOLD, WHEEL MOTOR
2	1	02203W	MANIFOLD SPACER
3	1	02201	SPOOL, DRIVE DUMP
4	1	10236	SPOOL SPACER
5	1	03055	SPRING, VALVE SPOOL RETURN
6	1	10614	QUAD RING #4-113
7	1	10470	QUAD RING #4-116
8	1	03225	O-RING, 2-116N70, 15-16 OD X 3/32 SECTION
9	1	03200	THRUST WASHER, .75 X 1 X .060, HARD
10	1	05216	SNAP RING, 3/4 EXTERNAL
11	4	03300	FITTING, 6409-4 PLUG
12	1	04533	FITTING, 6801-8-8-LL
13	1	04210	FITTING, 6802-8-8
14	4	03226	O-RING, 2-112N70, 11/16 OD X 3/32 SECTION
15	1	10237	SH CAP SCREW, 3/8-16 NC X 3/4 PLAIN
16	4	05362	SH CAP SCREW, 5/16-18 NC X 2-3/4 ZINC

1

UNITS WITH A WHITE BRAND WHEEL DRIVE MOTOR  
NEED MANIFOLD SPACER 02203W

UNITS WITH A CHAR-LYNN EATON BRAND WHEEL DRIVE MOTOR  
NEED MANIFOLD SPACER 02203CT

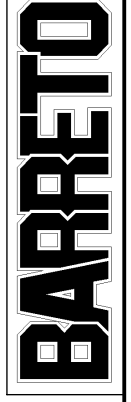
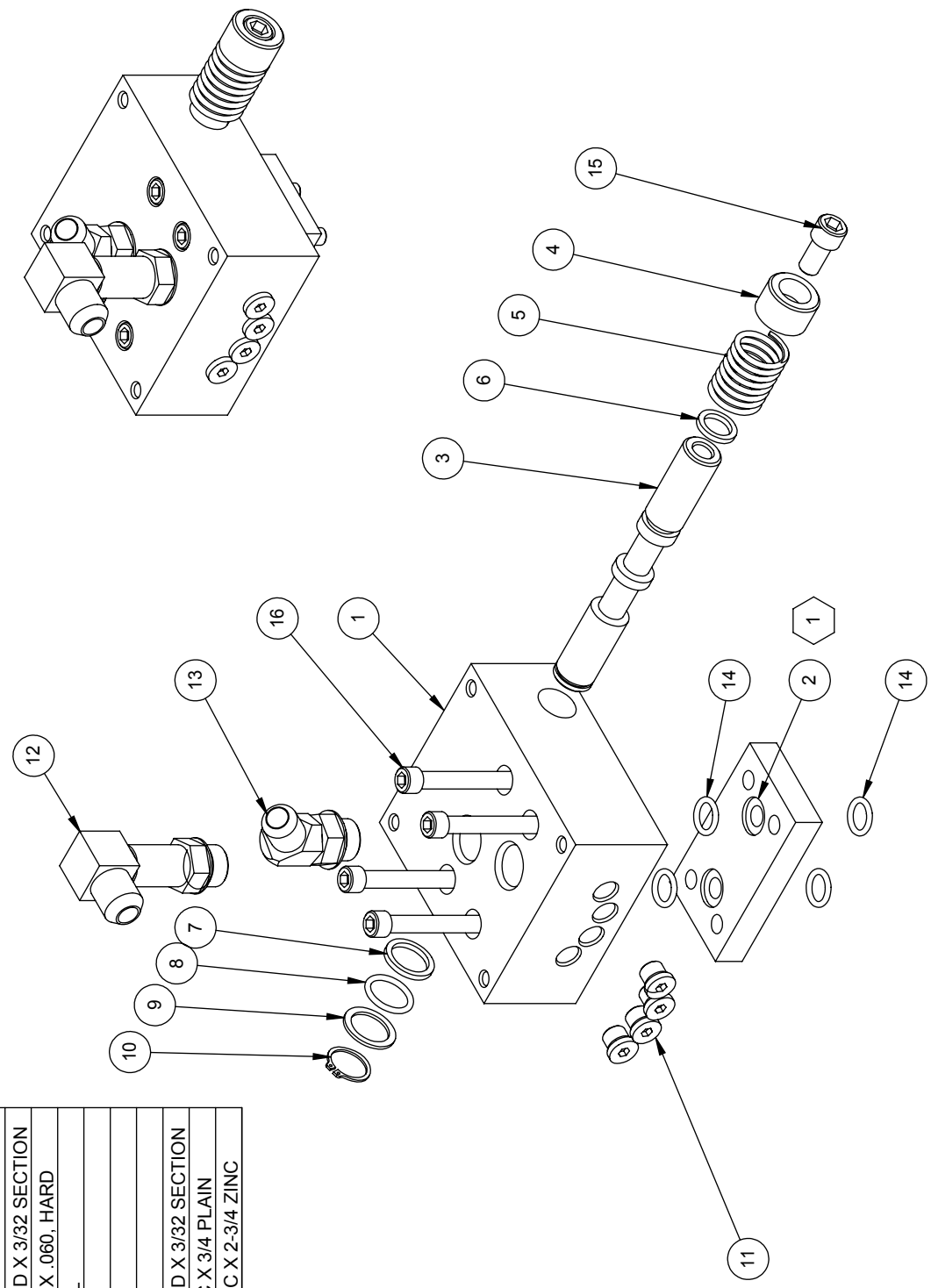

REF QTY.	PART NO.	DESCRIPTION
1	02269-HUB	WHEEL HUB ASSY, 1-1/8" BORE
2	03190-FW	TIRE & RIM, 16" X 4", LEFT HAND
3	03191-FW	TIRE & RIM, 16" X 4", RIGHT HAND
4	05042	NUT, LUG, 1/2-20 NF
5	02068	PIN, FREE WHEELING
6	05102	WASHER, 1/2 SAE ZINC HARDENED
7	05548	ROLL PIN (SLOTTED SPRING), 1/8 X 3/4 ZINC
8	03352	SPRING, CENTURY 3385
9	02083	SPACER, WHEEL
10	01077	MOUNTING PLATE, PIN, FREE WHEELING
11	03550	SPLIT RING-27

1 FOR TRENCHER, 03190-FW IS ON RIGHT SIDE, FOR TRENCHING IN REVERSE

2 FOR TRENCHER, 03191-FW IS ON LEFT SIDE, FOR TRENCHING IN REVERSE

03190-F = FOAM FILLED TIRE, LEFT  
03191-F = FOAM FILLED TIRE, RIGHT

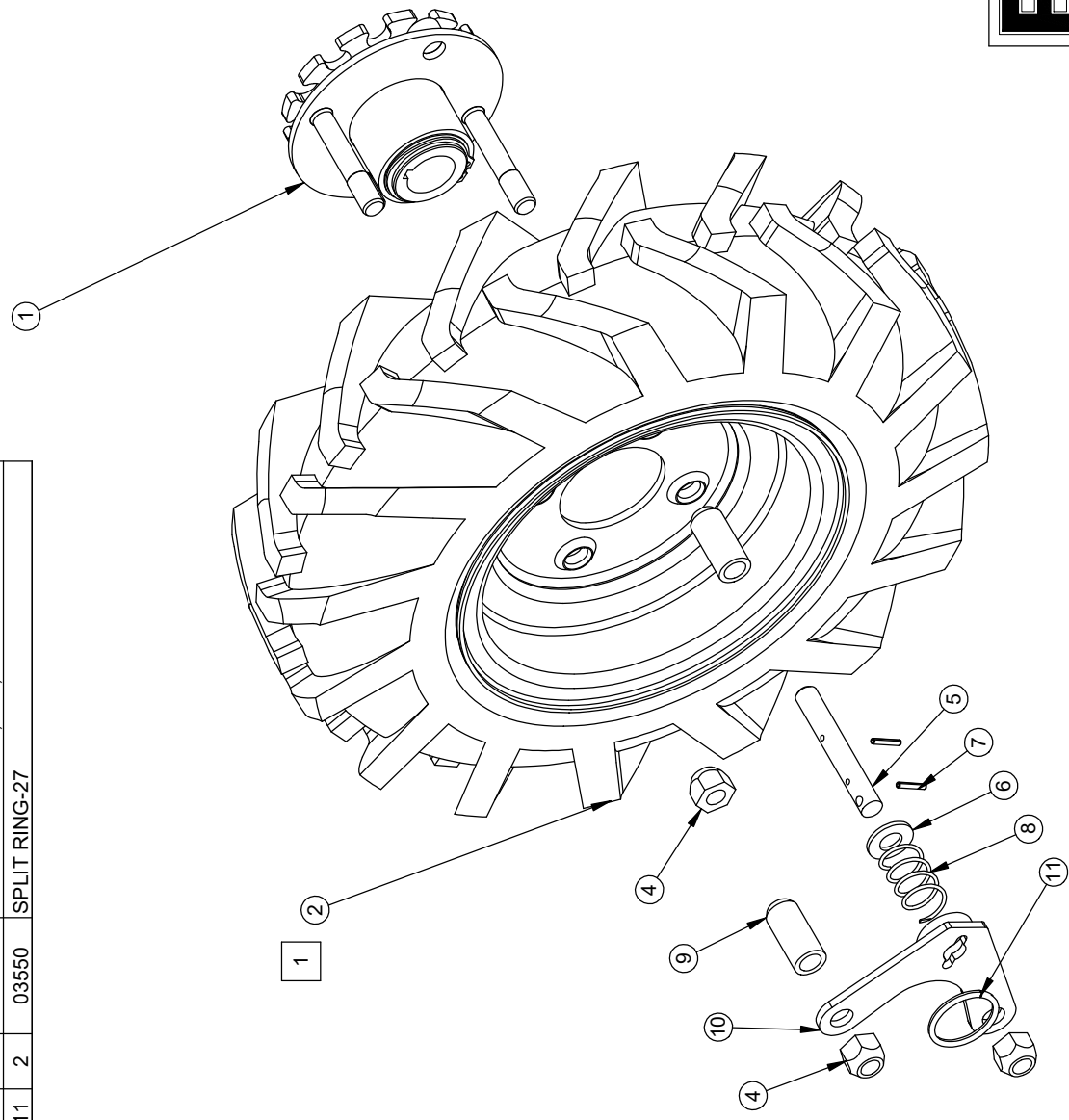
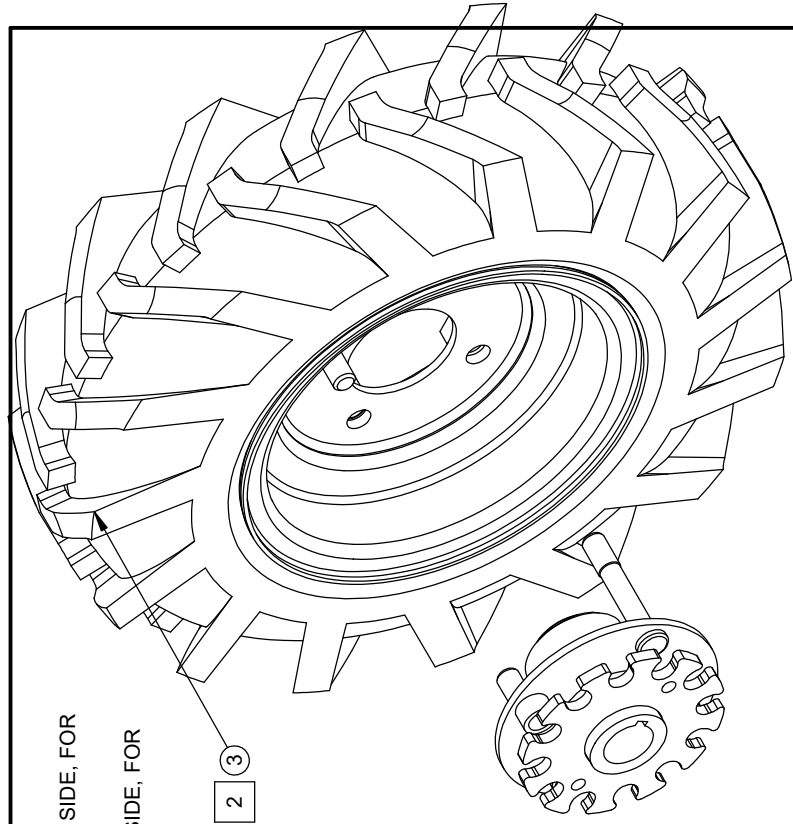

NOTES:

1. RIM ALONE IS PART NO. 03712.  
TIRE ALONE IS PART NO. 03193.
2. USAGE: 1 OF 00256 R1 PER 912, 916 & 918.

# BARRETO

TITLE: FREE WHEELING HUBS AND WHEELS

PRODUCT LINE: COMMON

SCALE: 1:4

SHEET 1 OF 1

DATE: 7/16/07

DWG# 00256 R1

UPDATED 10/5/16

REF	QTY.	PART NO.	DESCRIPTION
1	1	04513-M	VALVE RD-2508-M4, 2200 psi
2	1	04512-M	VALVE RD-2508-T4, 500-650 PSI
3	1	10553	CYLINDER VALVE LEVER
4	1	10330	VALVE LEVER
5	1	10335	VALVE ENGAGE LEVER
6	1	10337	VALVE ROCKER
7	1	11743	SPACER
8	2	03509	BRACKET & PINS, COMES WITH VALVE
9	3	03026	KNOB, 5/16-NC
10	1	04523	FITTING, 4601-12-10
11	2	04529	FITTING, 6410-8-6
12	2	04527-01	FITTING, 6801-4-6
13	1	04521	FITTING, 6407-10-10
14	2	04554	FITTING, 6801-8-8
15	1	04211	FITTING, 6801-8-10
16	1	10345	CLEVIS PIN, 1/4 X 3/4 ZINC
17	1	05081	WASHER, 1/4 SAE ZINC
18	1	05038	RUE RING COTTER #8
19	1	05069	WHIZ-LOCK 1/4 - 20 X 5/8
20	1	05535	WHIZ-LOCK 1/4 - 20 X 7/8
21	1	05049	WHIZ-LOCK 1/4 - 20 X 3/4
22	2	05101	WASHER, 3/8 SAE ZINC
23	1	05096	NUT, NYLOCK, 1/4-20 NC ZINC
24	1	10773	NUT, GRIPCO, 1/4-20 NC G5 ZINC

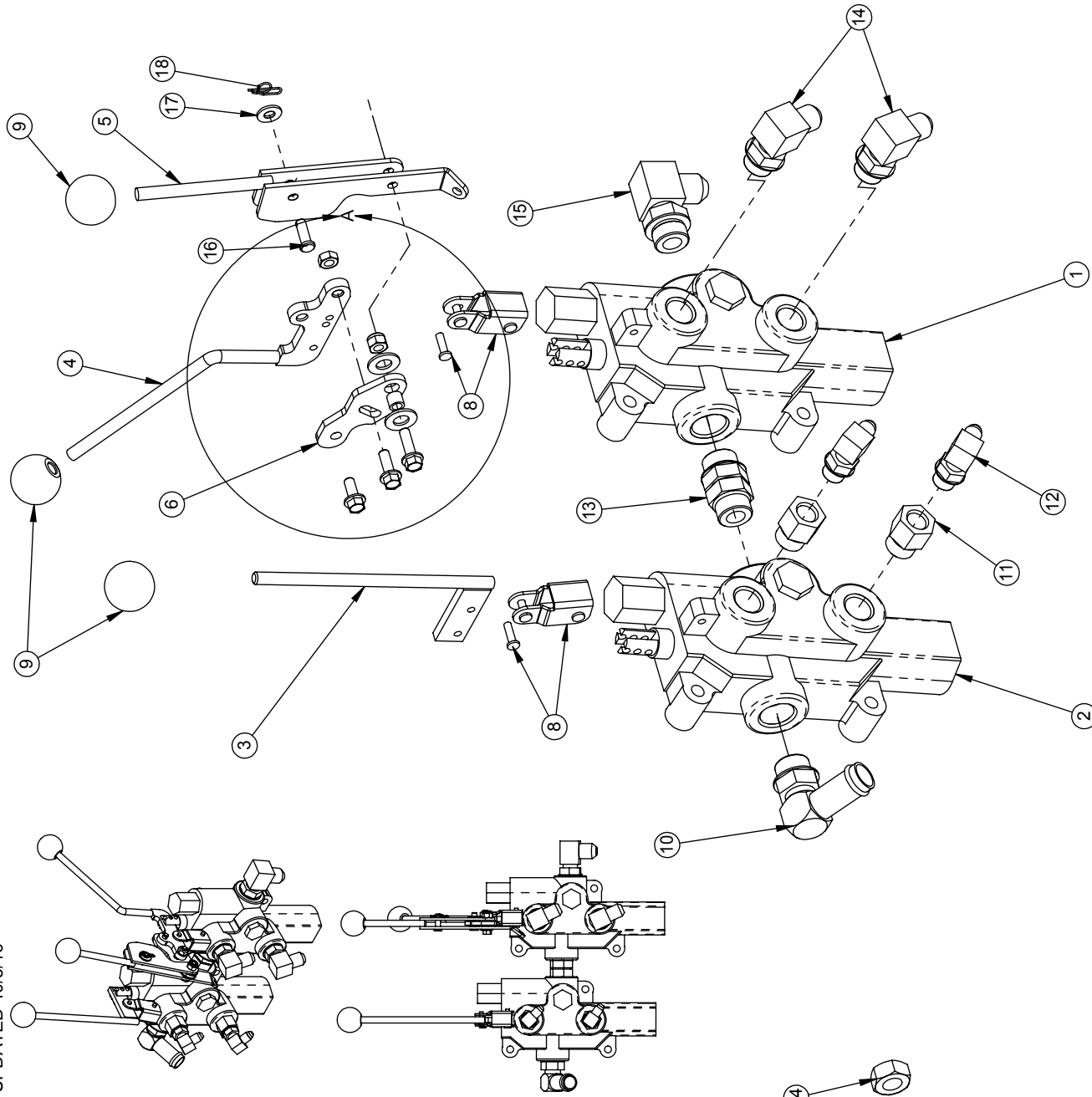

TITLE: CONTROL VALVE ASSEMBLY

PRODUCT LINE: TRENCHER 912

DATE: 8/24/04

SCALE: 1:4

DWG# 00259

SHEET 1 OF 1

**BARRETO**

DETAIL A  
SCALE 1:2

REF QTY.	PART NO.	DESCRIPTION	REF QTY.	PART NO.	DESCRIPTION
1	00259	CONTROL VALVE ASSEMBLY	49	05054	HH CAP SCREW, 5/16-18 NC X 1-3/4 G5 ZINC
2	00273	SPEED LEVER ASSEMBLY	50	05068	WASHER, 5/16 SAE ZINC
3	01503K	CLUTCH LEVER KIT	51	05273	NUT, NYLOCK, 5/16-18 NC ZINC
4	10327	CONTROL POD	52	05069	WHIZ-LOCK 1/4 - 20 X 5/8
5	10534	HOSE COVER	53	05096	NUT, NYLOCK, 1/4-20 NC ZINC
6	01402-R	HANDLE BAR, RH	54	05081	WASHER, 1/4 SAE ZINC
7	01402-L	HANDLEBAR, LEFT	55	05233	SCREW #10-24 X 1/2 PPH
8	01403	HANDLE BAR SLUG			
9	10331	VALVE LINKAGE			
10	10332	LINK PIVOT			
11	10346	LINKAGE PIVOT			
12	10549	BACK COVER			
13	03009-R1	HOUR METER, WITH FLASH ALERT			
14	12090	INSTRUCTION CANISTER			
15	03505	CABLE, 4-1/2"			
16	06423	STARTER GROMMET			
17	10548	SPRING LEE LE-055E-6MM			
18	03515-T	THROTTLE CABLE			
19	03501	BUSHING, IGUS MFI-0810-08			
20	03514	CABLE, 40"			
21	04440-04	DECAL, DIG CHAIN ON/OFF			
22	04430-05	DECAL, DIG CHAIN FWD-N-REV			
23	04440-05	DECAL, THROTTLE CONTROL			
24	04440-06	DECAL, "TRAVEL F-N-R"			
25	04440-07	DECAL, "REV/TRENCH SYMBOL"			
26	03032	HANDLE BAR GRIPS (SOLD IN PAIRS)			
27	03341-07	DECAL, "IGNITION OFF/ON"			
28	03341-12	DECAL, "DIGGING BOOM, UP-DOWN"			
29	03341-24	DECAL, "WARNING - NO PARKING BRAKE"			
30	03040-01	DECAL, "MADE IN USA"			
31	03040-02	DECAL, "BARRETO", 3-1/2 X 11-1/4			
32	03345	DECAL, "CALL 811 BEFORE YOU DIG"			
33	04526-01	FITTING, 6801-6-4			
34	03951	FILTER, HYDRAULIC OIL, WITH BY-PASS			
35	04212-OR-U	FILTER HEAD, #12 O-RING, BOTH TAPPED			
36	04217	FITTING, 4604-16-12			
37	10362	FITTING, 4603-12-12			
38	10367	HOSE, RETURN, 04298			
39	05225	CLAMP, 1" ID HOSE, CTB-35 ST			
40	10368	RETURN HOSE, 04294			
41	05008	CLAMP, 1" HOSE, CTB-29			
42	06420	ROCKER SWITCH, IGNITION OFF/ON			
43	03806	QUICK-SPLICE			
44	06421	GROUND WIRE, IGNITION SWITCH			
45	10603	IGNITION WIRE, 912			
46	05038	RUE RING COTTER #8			
47	05059	HH CAP SCREW, 3/8-16 NC X 1 G5 ZINC			
48	05101	WASHER, 3/8 SAE ZINC			

UPDATE 12/12/16

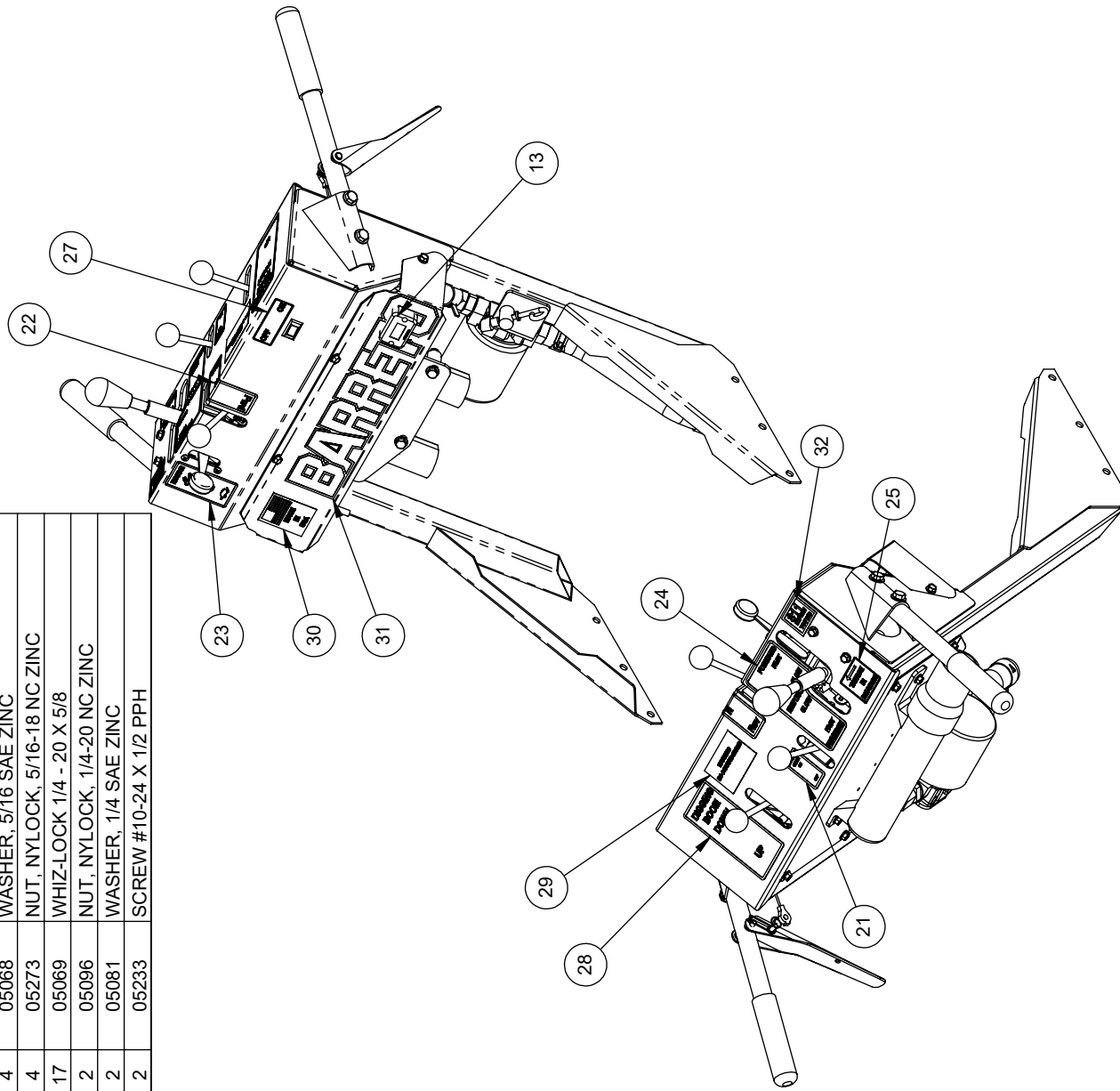

# BARRETO

TITLE: CONTROL ASSEMBLY

PRODUCT LINE: TRENCHER 912

DATE: 3/19/04

SCALE: 1:9

SHEET 1 OF 2

DWG# 00260

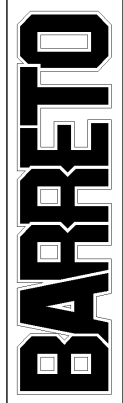
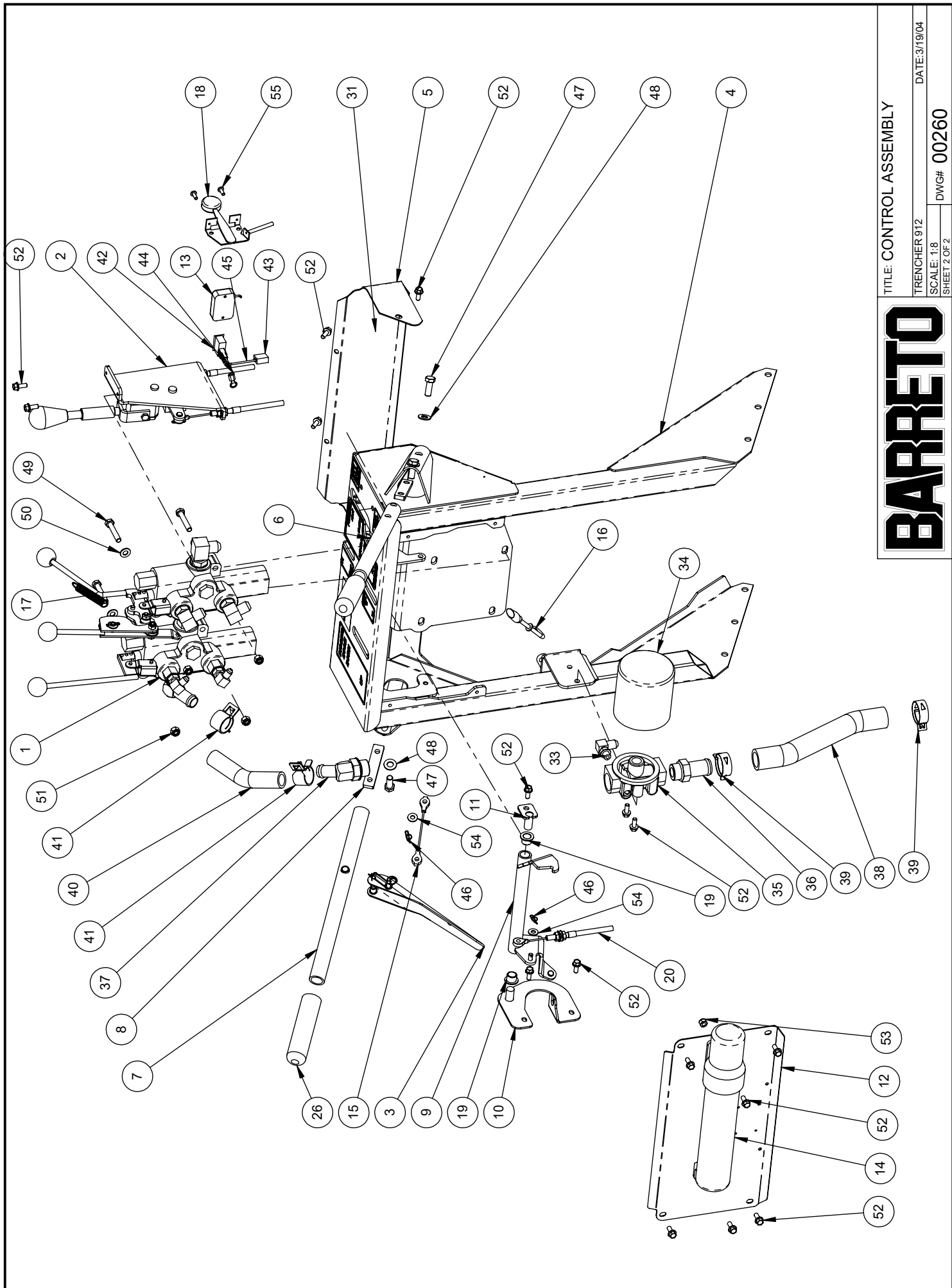

UPDATED: 4/20/23

NOTES:  
 04504 TANDEM ADAPT KIT INCLUDES  
 PLATE, COUPLER, O-RINGS, BOLTS, WASHERS  
 03021 & 03023 COUPLERS INCLUDE SET SCREW  
 [1] REF. 4 04504 REPLCEED BY 04504-MK

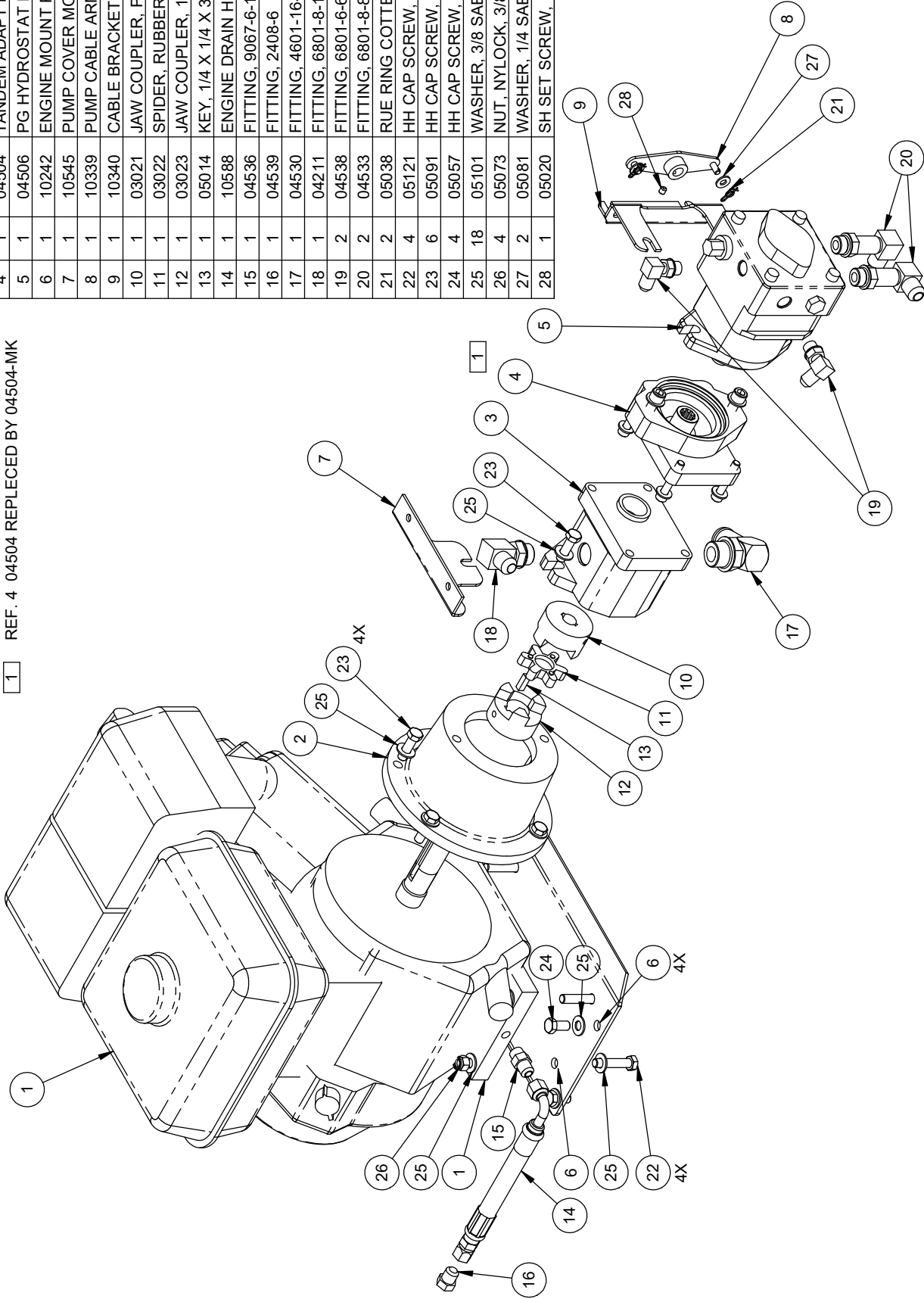

REF	QTY.	PART NO.	DESCRIPTION
1	1	07006	ENGINE, 9 HP HONDA GX270
2	1	02016	PUMP ADAPTER
3	1	04507	PUMP SNP2-8.5-HSTAT
4	1	04504	TANDEM ADAPT KIT
5	1	04506	PG HYDROSTAT PUMP .63 CI
6	1	10242	ENGINE MOUNT PLATE
7	1	10545	PUMP COVER MOUNT
8	1	10339	PUMP CABLE ARM
9	1	10340	CABLE BRACKET
10	1	03021	JAW COUPLER, PUMP, 5/8" BORE
11	1	03022	SPIDER, RUBBER
12	1	03023	JAW COUPLER, 1" BORE L095
13	1	05014	KEY, 1/4 X 1/4 X 3/4
14	1	10588	ENGINE DRAIN HOSE
15	1	04536	FITTING, 9067-6-12METRIC
16	1	04539	FITTING, 2408-6
17	1	04530	FITTING, 4601-16-12
18	1	04211	FITTING, 6801-8-10
19	2	04538	FITTING, 6801-6-6
20	2	04533	FITTING, 6801-8-8-LL
21	2	05038	RUE RING COTTER #8
22	4	05121	HH CAP SCREW, 3/8-16 NC X 1-3/4 G5 ZINC
23	6	05091	HH CAP SCREW, 3/8-16 NC X 1-1/4 G5 ZINC
24	4	05057	HH CAP SCREW, 3/8-16 NC X 3/4 G5 ZINC
25	18	05101	WASHER, 3/8 SAE ZINC
26	4	05073	NUT, NYLOCK, 3/8-16 NC ZINC
27	2	05081	WASHER, 1/4 SAE ZINC
28	1	05020	SH SET SCREW, 1/4-20 NC X 1/4" CUP POINT



TITLE: ENGINE & PUMPS ASSEMBLY

PRODUCT LINE: TRENCHER 912  
 SCALE: 1:6  
 SHEET 1 OF 1  
 DWG# 00261  
 DATE: 3/17/04

RELEASE DATE	01/20/2022
REVISED DATE	NEW
REVISION #	0

ITEM NO.	PART NUMBER	DESCRIPTION	QTY.
1	02016	PUMP ADAPTER	1
2	04507	PUMP SNP2-8.5-HSTAT	1
3	04504	TANDEM ADAPT KIT	1
4	04506	PG HYDROSTAT PUMP .63 CI	1
5	10545	PUMP COVER MOUNT	1
6	10339	PUMP CABLE ARM	1
7	10340	CABLE BRACKET	1
8	03021	JAW COUPLER, PUMP, 5/8" BORE	1
9	03022	SPIDER, RUBBER	1
10	03023	JAW COUPLER, 1" BORE L095	1
11	05014	KEY, 1/4 X 1/4 X 3/4	1
12	10588	ENGINE DRAIN HOSE	1
13	04539	FITTING, 2408-6	1
14	04530	FITTING, 4601-16-12	1
15	04211	FITTING, 6801-8-10	1
16	04538	FITTING, 6801-6-6	2
17	04533	FITTING, 6801-8-8-LL	2
18	05038	RUE RING COTTER #8	2
19	05054	HH CAP SCREW, 5/16-18 NC X 1-3/4 G5 ZINC	4
20	05091	HH CAP SCREW, 3/8-16 NC X 1-1/4 G5 ZINC	6
21	05057	HH CAP SCREW, 3/8-16 NC X 3/4 G5 ZINC	4
22	05101	WASHER, 3/8 SAE ZINC	10
23	05081	WASHER, 1/4 SAE ZINC	2
24	05020	SH SET SCREW, 1/4-20 NC X 1/4" CUP POINT	1
25	07036	ENGINE, BRIGGS VANGUARD 10HP	1
26	10242B	BRIGGS 10HP MOUNT PLATE	1
27	10186	ENGINE LIFT EYE	1
28	04617	HYD ADAPTER 2404-6-6	1
29	05068	WASHER, 5/16 SAE ZINC	4
30	05273-F	NUT, 5/16-18 NC, NYLOCK FLANGE, ZN	4

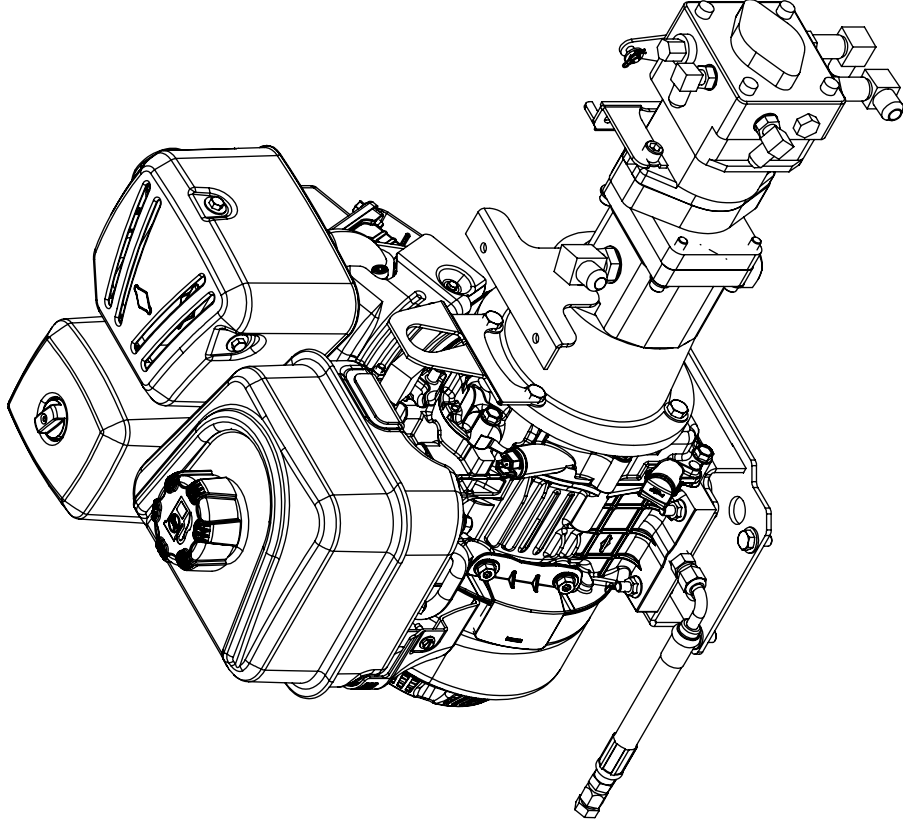

# BARRETO

TITLE: ENGINE & PUMP ASSEMBLY, BRIGGS

PRODUCT LINE: 912 TRENCHER

SCALE: 1:6

SHEET 1 OF 3

DWG# 00261-B

TITLE: ENGINE & PUMP ASSEMBLY, BRIGGS

PRODUCT LINE: 912 TRENCHER

SCALE: 1:6

DWG# 00261-B

# BARRETO

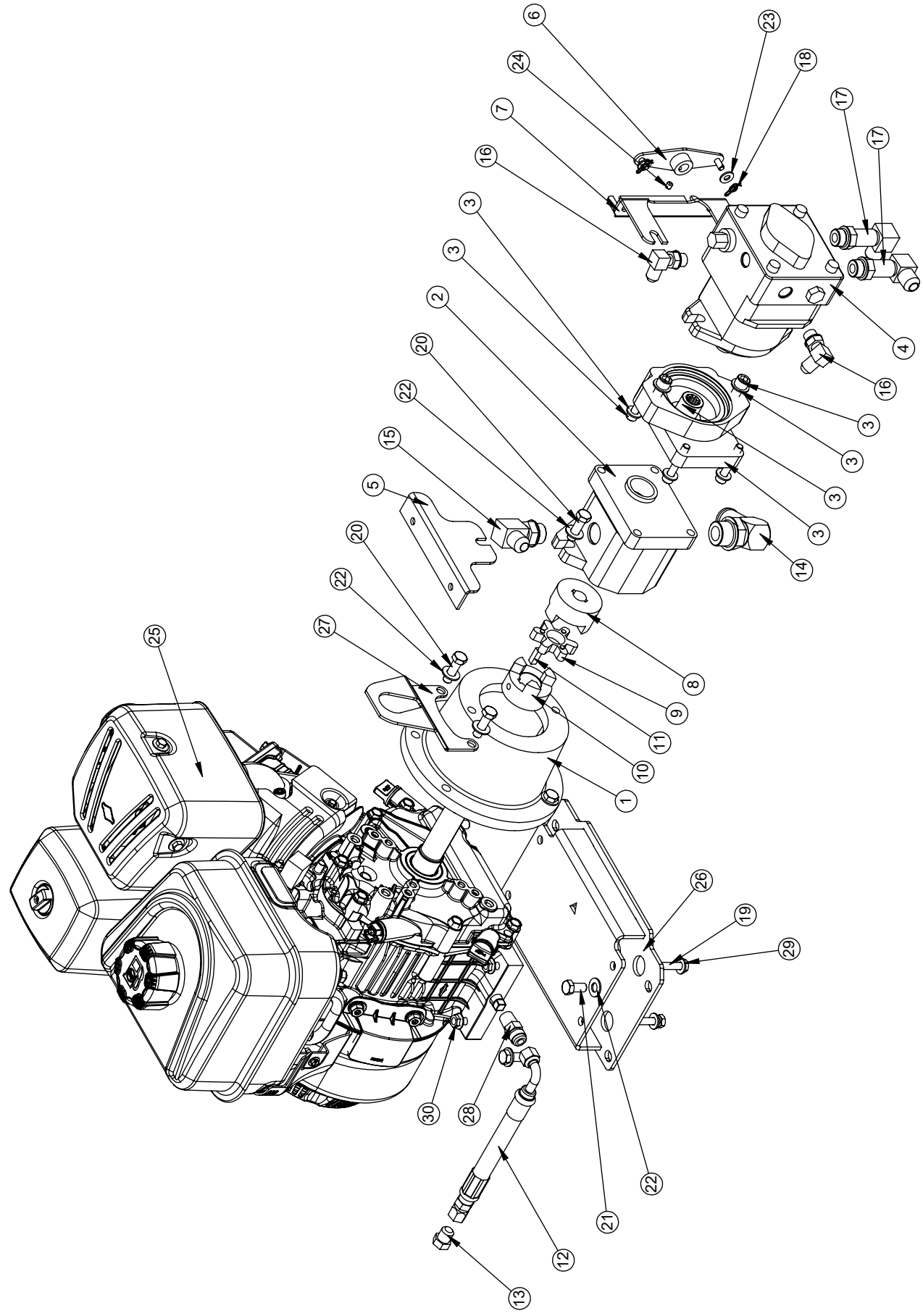

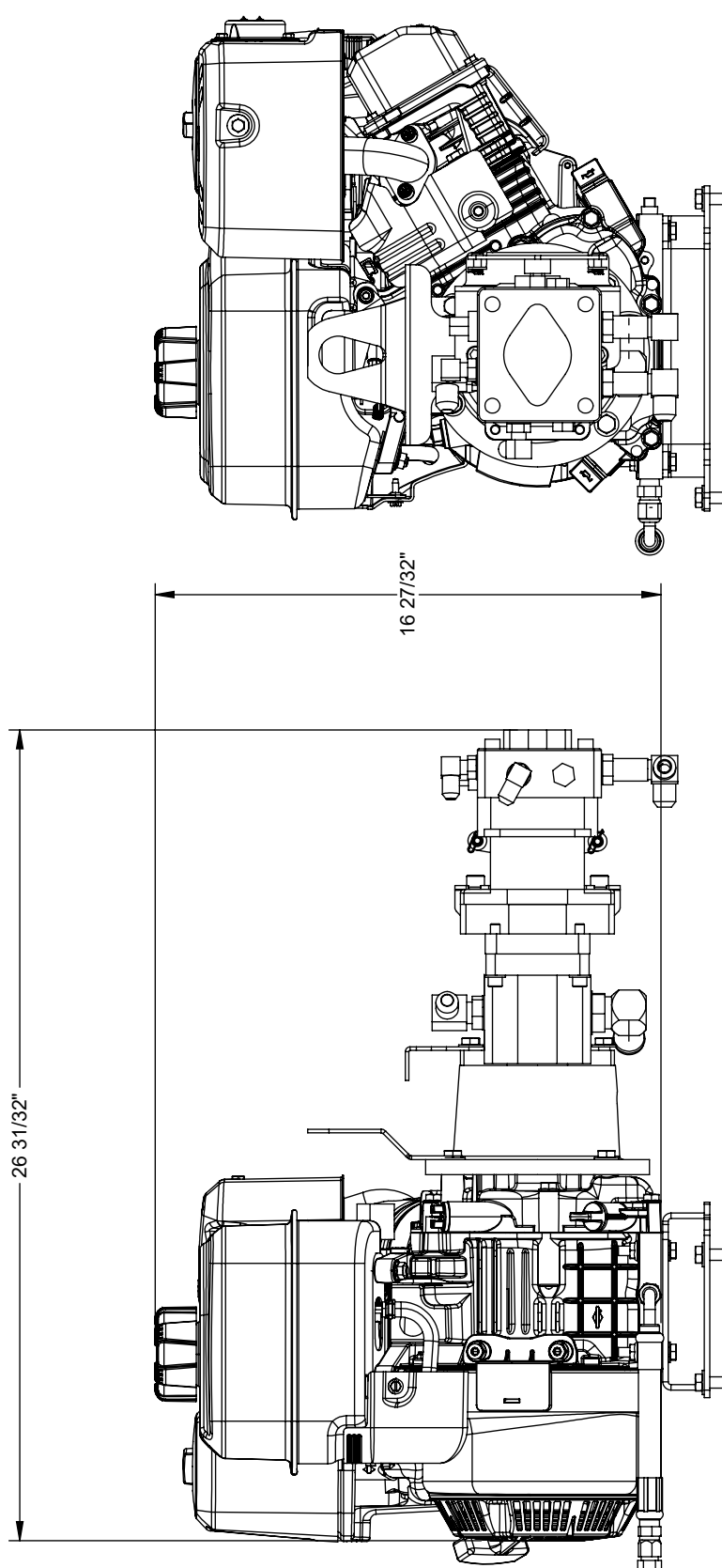

TITLE: ENGINE & PUMP ASSEMBLY, BRIGGS

PRODUCT LINE: 912 TRENCHER

SCALE: 1:6

SHEET: 3 OF 3

DWG# 00261-B

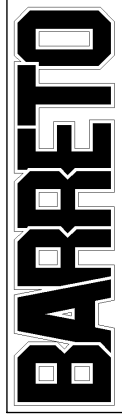

FOR OUR MOST POPULAR CHAIN OPTIONS SEE THE LAST PAGE OF THIS MANUAL  
OR CALL US AT 1-800-525-7348 FOR ADDITIONAL OPTIONS.

DIG DEPTH:

- 12" BOOM GUARD 10325
- 18" BOOM GUARD 10650
- 24" BOOM GUARD 10866 R1

- 12" BOOM 10316
- 18" BOOM 10649
- 24" BOOM 10865 R1

ITEM NO.	QTY.	PART NO.	DESCRIPTION
1	1	100265	ROLLER ASSEMBLY
2	1	DIG CHAIN	CHAIN OPTIONS
3	1	10325	BOOM GUARD 12"
4	1	10316	BOOM - 12"
5	1	10567	CRUMBER ARM
6	2	10564	CRUMBER MOUNT
7	1	10270	CUSHION, BOOM
8	1	10318	BOOM CUSHION WASHER
9	3	04440-02	DECAL: DANGER, BOOM GUARD
10	2	10586	CLEVIS PIN, 1/2 X 2-3/4 ZINC
11	2	05102	WASHER, 1/2 SAE ZINC HARDENED
12	2	05222	COTTER PIN 1/8 X 3/4
13	1	10319	CHAIN TENSION SCREW
14	1	10326	NUT, 1/2-13 NC G5 ZINC
15	3	05091	HH CAP SCREW, 3/8-16 NC X 1-1/4 G5 ZINC
16	3	05073	NUT, NYLOCK, 3/8-16 NC ZINC
17	2	05089	HH CAP SCREW, 5/16-24 NF X 2-1/4 G5 ZINC
18	2	10462	NUT, GRIPCO, 5/16-24 NF G5 ZINC

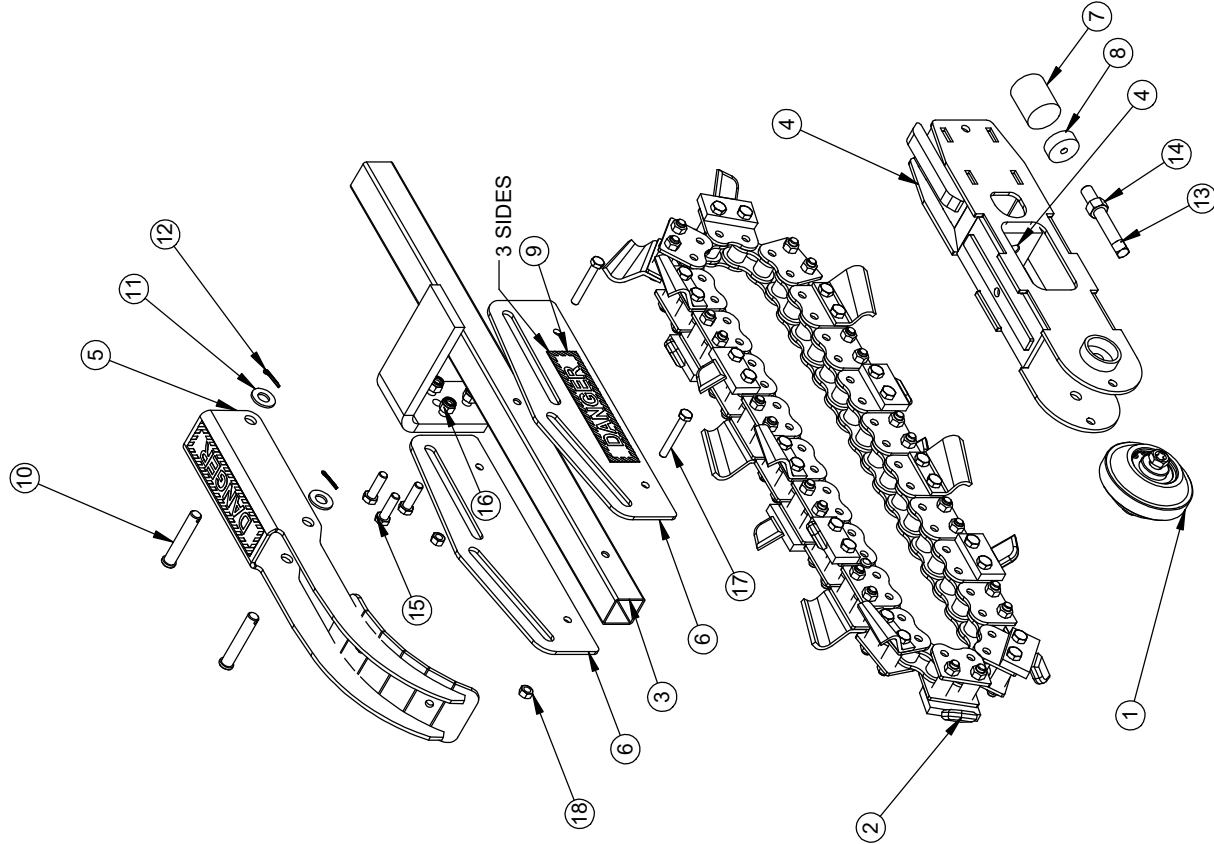
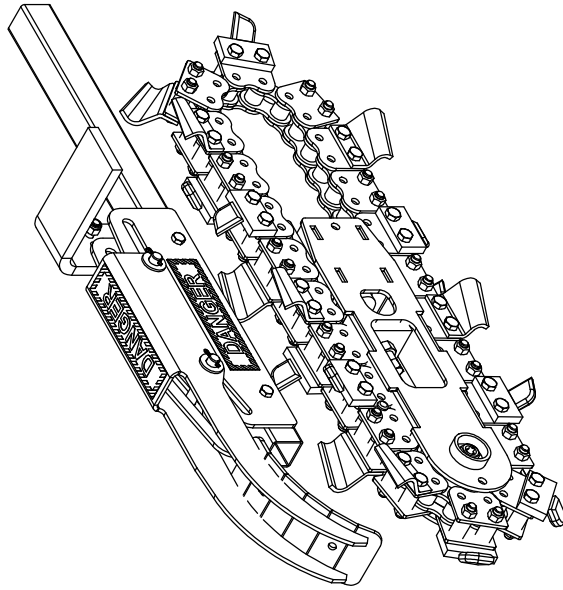

RELEASE DATE	10/6/16
REVISED DATE	NEW
REVISION #	0

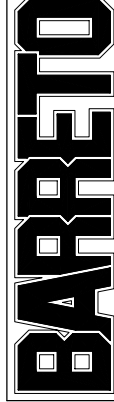

TITLE: BOOM GUARD & CRUMBER  
 PRODUCT LINE: 912  
 SCALE: 1:8  
 SHEET 1 OF 1  
 DWG# 00262-GUARD

RELEASE DATE	3/17/04
REVISED DATE	10/10/16
REVISION #	1

ITEM NO.	QTY.	PART NO.	DESCRIPTION
1	1	00262-BOOM	BOOM GUARD & CRUMBER
2	1	00264	MOTOR HOUSING ASSEMBLY
3	1	00271	CYLINDER ASSEMBLY
4	1	10273	FRONT END MOUNT
5	1	10286-W	AUGER SPACER, WIDE
6	1	10287	AUGER
7	1	10280	PIVOT PIN
8	1	10626	PIVOT PIN WASHER
9	1	10627	C-SINK HD CAP SCR. 31 X .75 NC Z
10	2	10281	CYLINDER PIN
11	1	10546	CYLINDER ROD PIN
12	1	11962	FLAP CLAMP
13	1	03903	FLAP
14	1	10347	TIRE & RIM 4.10/3.50-4
15	2	10347.50	BEARING, 1/2 BORE
16	1	04440-03	DECAL; 912
17	1	03341-05	DECAL; DANGER, CHAIN
18	2	05044	GREASE ZERK, 1/4-28 UNF
19	1	05307	GREASE ZERK, 1/4-28 UNF 90°
20	4	10740	HH CAP SCREW, 3/8-24 NF X 3-1/2 G5 ZINC
21	4	05304	HH CAP SCREW, 5/16-18 NC X 1/2 G5 ZINC
22	1	05169	WHIZ-LOCK 5/16 - 18 X 1/2
23	4	05237	HH CAP SCREW, 1/4-20 NC X 1 G5 ZINC
24	4	05081	WASHER, 1/4 SAE ZINC
25	4	05096	NUT, NYLOCK, 1/4-20 NC ZINC
26	1	10458-S	FRONT AXLE
27	2	05131	HHFS 5/16-18 X 1/2, G5, ZN

SEE DRAWING 00262-BOOM FOR BOOM & BOOM GUARD OPTIONS  
SEE THE LAST PAGE OF THIS MANUAL FOR OUR MOST POPULAR CHAIN OPTIONS

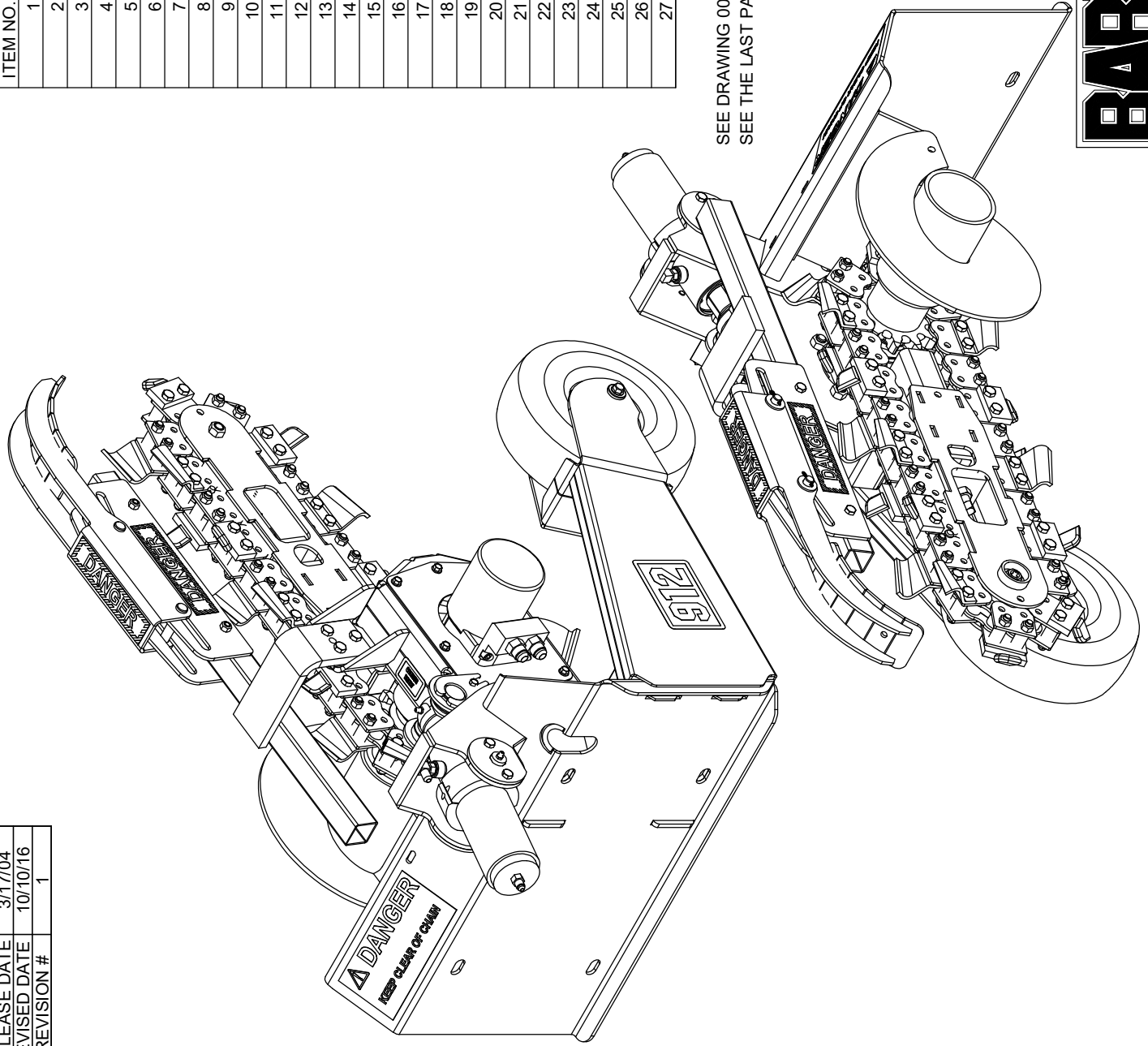

# BARRETO

TITLE: FRONT END

PRODUCT LINE: 912 TRENCHER

SCALE: 1:8  
SHEET 1 OF 2  
DWG# 00262

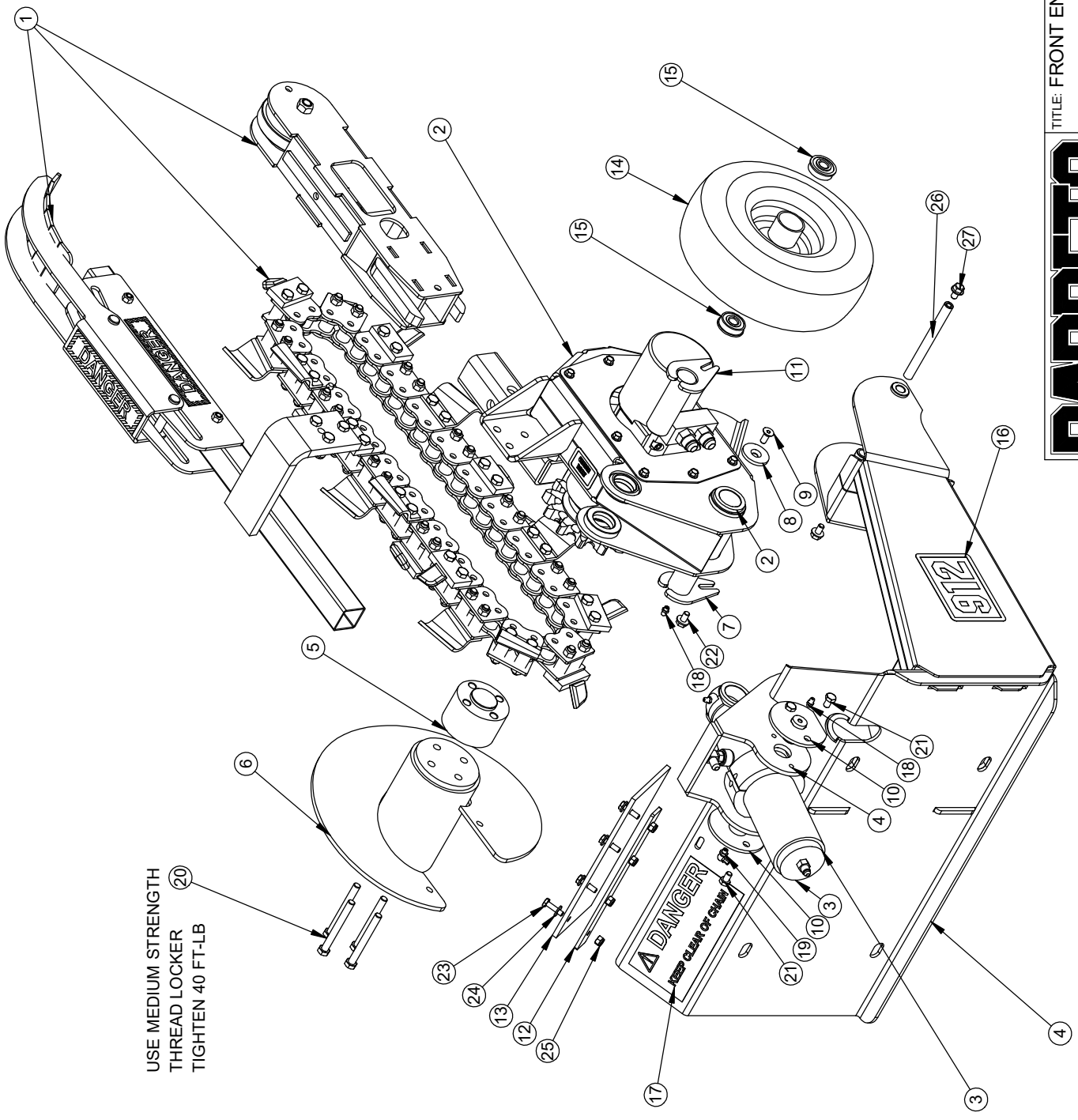

USE MEDIUM STRENGTH  
 THREAD LOCKER (20)  
 TIGHTEN 40 FT-LB

TITLE: FRONT END  
 PRODUCT LINE: 912 TRENCHER  
 SCALE: 1:8  
 SHEET 2 OF 2  
 DWG# 00262

**BARRETO**

REF	QTY.	PART NO.	DESCRIPTION
1	4	05361	SH CAP SCREW, 5/16-18 NC X 7/8 ZINC
2	2	03226	O-RING, 2-11/2N70, 11/16 OD X 3/32 SECTION
3	1	10285	SEAL CR22550
4	1	10284	SNAP RING, HO-334, 3-11/32 INTERNAL
5	1	05603	SNAP RING, HO-315, 3-5/32 INTERNAL
6	1	05607	SNAP RING, SH-156, 1-9/16" EXTERNAL
7	1	10253	BALL BEARING, SKF 6209
8	1	03943	BALL BEARING, SKF 6208
9	1	02065	MANIFOLD, TINE MOTOR
10	1	10450-P	MOTOR, PARKER TB 0195, 11.9 CI
11	1	10254	HOUSING TUBE
12	1	10252	SPROCKET SPINDLE
13	1	10689	O-RING, 2-042, 3-3/8 OD X 1/16 SECTION
14	2	03302	FITTING, 6409-6 PLUG
15	2	05585	SH CAP SCREW, 1/2-13 NC X 1-1/4 ZINC
16	4	05167	STUD, KNURLED 1/2-20 X 1-13/16, PLT
17	1	05044	GREASE ZERK, 1/4-28 UNF

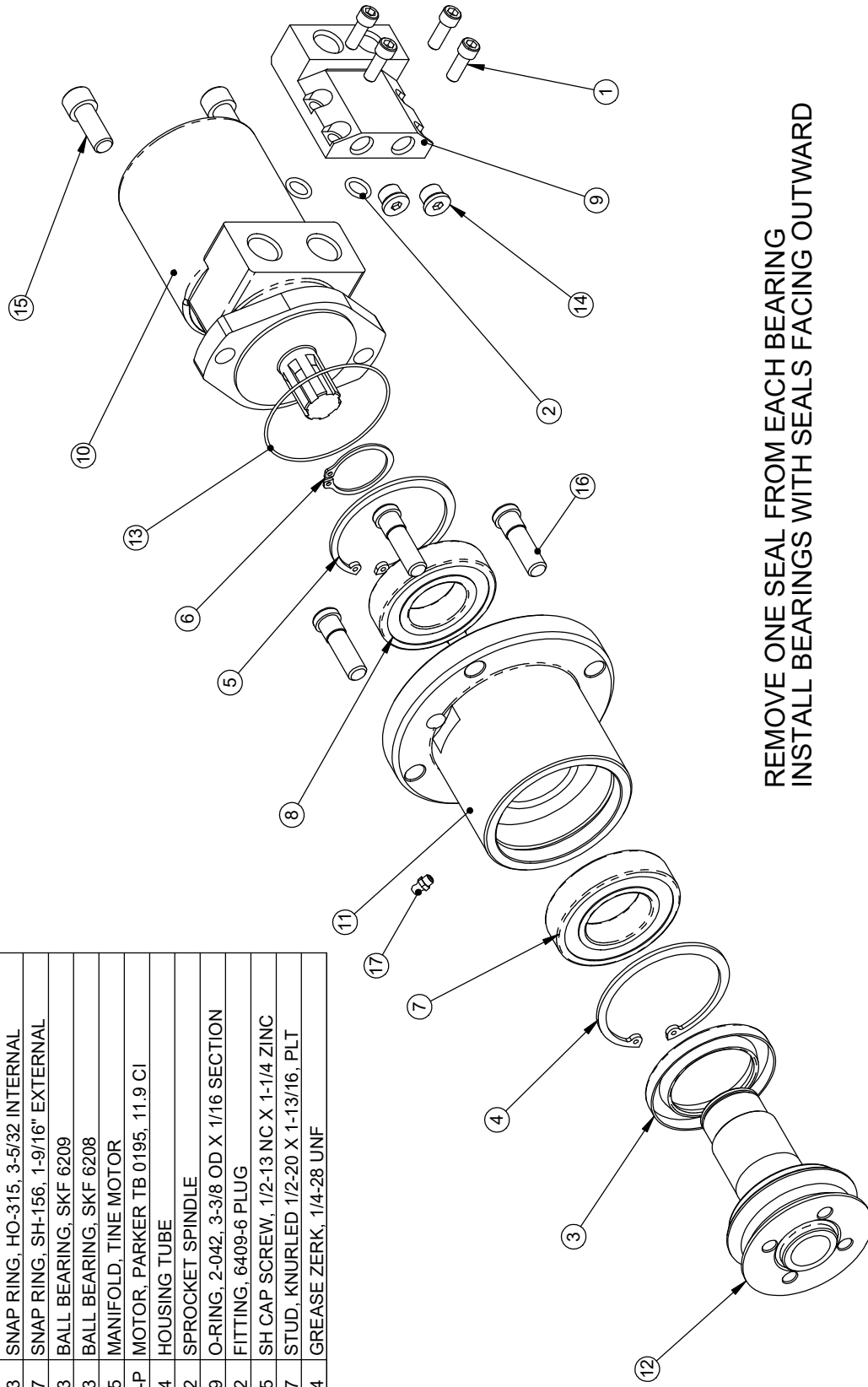

REMOVE ONE SEAL FROM EACH BEARING  
 INSTALL BEARINGS WITH SEALS FACING OUTWARD

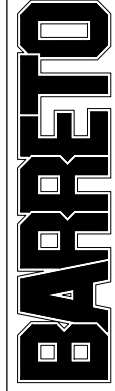

TITLE: MOTOR / SHAFT ASSEMBLY

PRODUCT LINE: TRENCHER 912

DATE: 7/14/21

SCALE: 1:4

DWG#: 00263

SHEET 1 OF 1

UPDATED 10/10/16  
PARKER MOTOR 7-14-21

REF QTY.	PART NO.	DESCRIPTION
1	00263	MOTOR/SHAFT ASSEMBLY
2	10255	CHAIN MOTOR HOUSING
3	10248	DIG SPROCKET 100A12
4	10283	HOUSING COVER
5	10277	BUSHING, IGUS JFI-2024-17
6	04520	FITTING, 6400-8-8
7	03040-04	DECAL, "GREASE DAILY"
8	10601	BRACE BOLT
9	11056	NUT, JAM, 1/2-13 NC G5 ZINC
10	05076	NUT, GRIPCO, 1/2-20 NF G5 ZINC
11	05069	WHIZ-LOCK 1/4 - 20 X 5/8

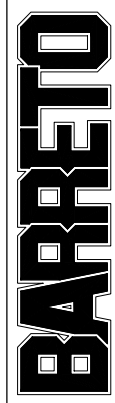
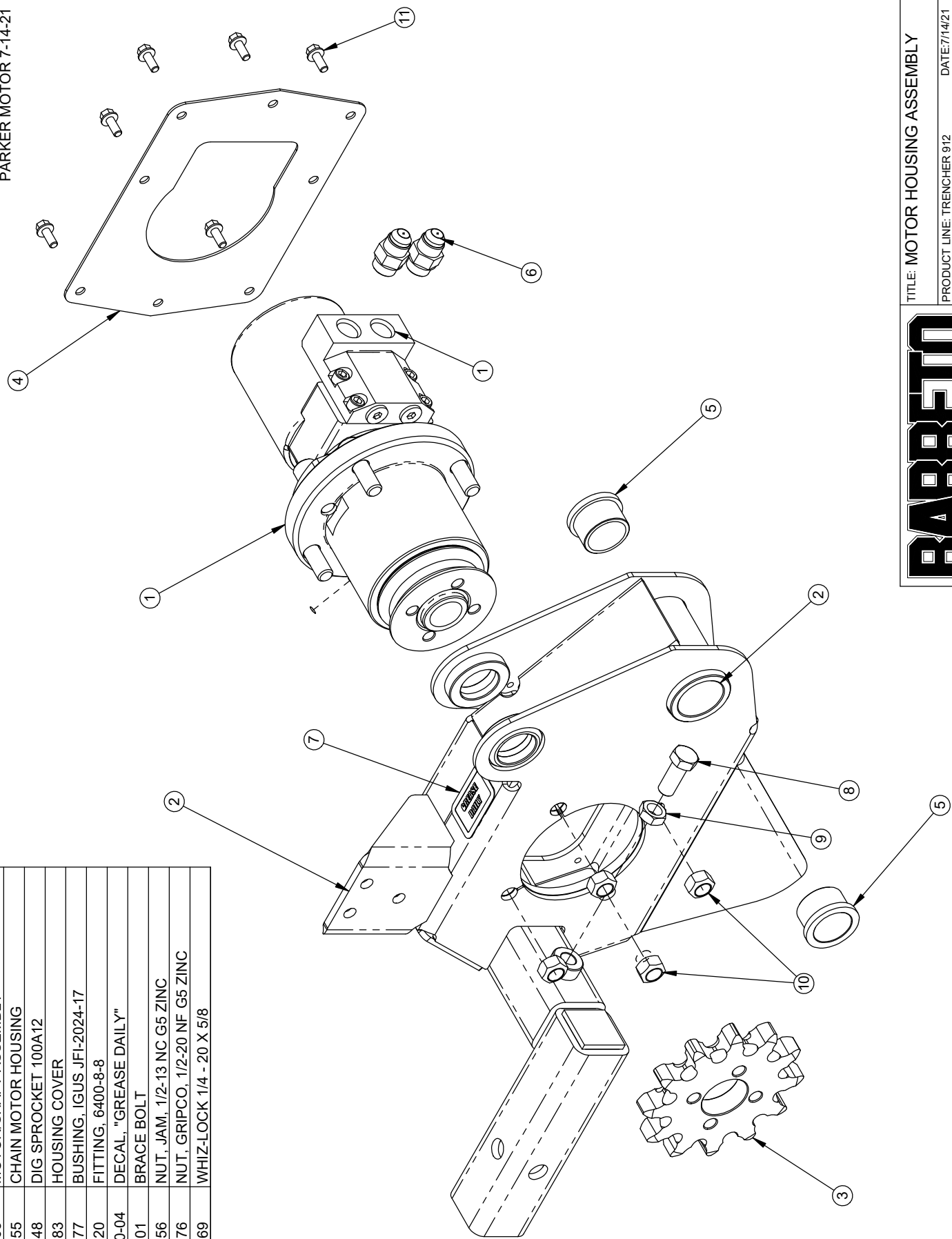

TITLE: MOTOR HOUSING ASSEMBLY

PRODUCT LINE: TRENCHER 912 DATE: 7/14/21

SCALE: 1:4 DWG#: 00264

SHEET 1 OF 1

△ 01039 SHIELD WAS 01026

UPDATED 10/10/16

REF QTY.	PART NO.	DESCRIPTION
1	10311	CHAIN ROLLER
2	10320	ROLLER AXLE
3	10312	ROLLER SPACER
4	10887	O-RING, 2-020N70, 1 OD X 1/16 SECTION
5	01039	SHIELD, ROLLER BEARING
6	03043	BALL BEARING, 6205
7	05024	SNAP RING, HO-200, 2" INTERNAL
8	05044	GREASE ZERK, 1/4-28 UNF
9	05046	NUT, GRIPCO, 1/2-13 NC G5 ZINC

REMOVE ONE SEAL FROM EACH BEARING  
 INSTALL BEARINGS WITH SEAL FACING OUTWARD

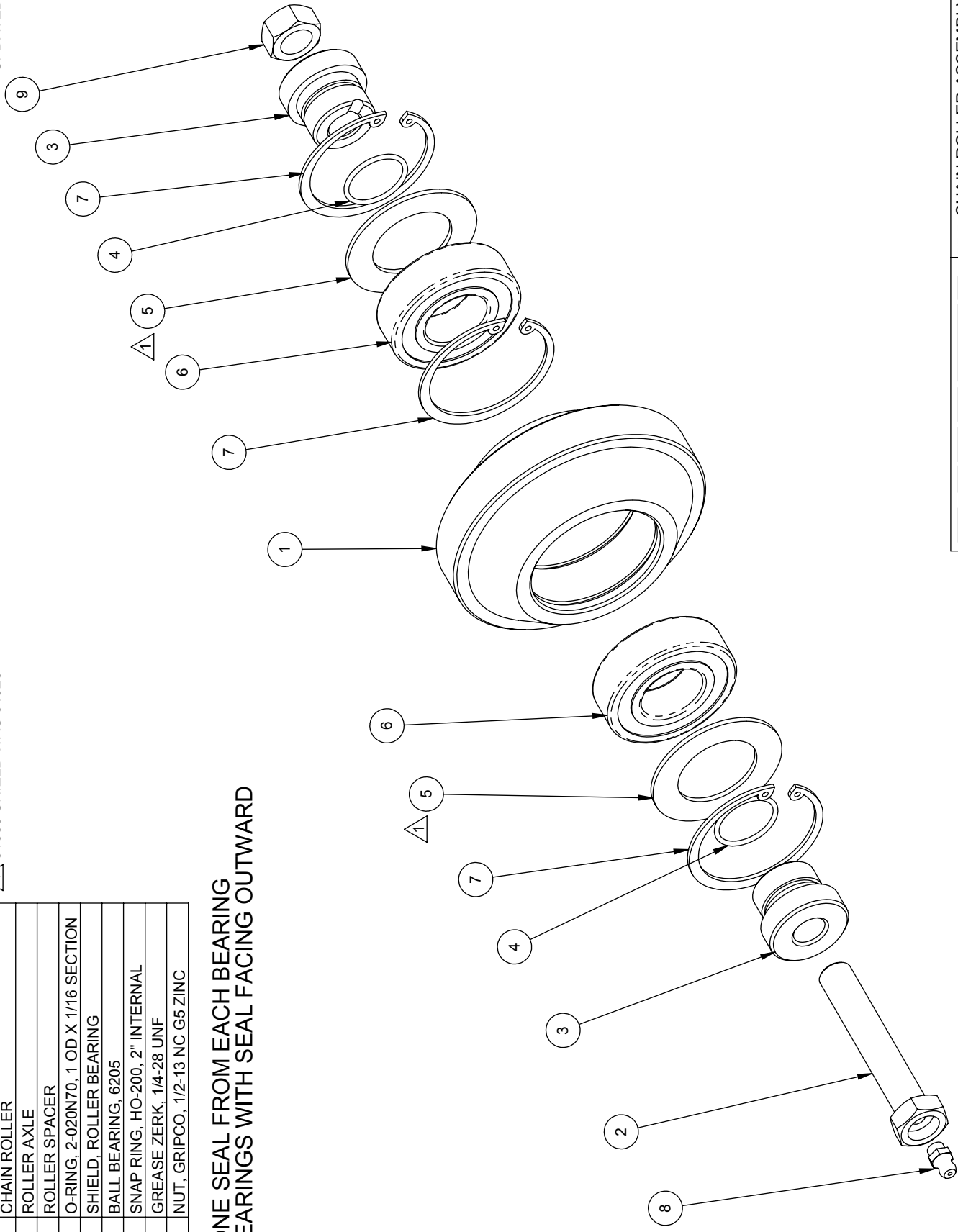

TITLE: CHAIN ROLLER ASSEMBLY

PRODUCT LINE: TRENCHEUR 912 DATE: 3/11/04

SCALE: 1:2 DWG#: 00265

SHEET 1 OF 1

1 03293 O-RING IS INCLUDED WITH 10247 SUMP SCREEN

REF QTY.	PART NO.	DESCRIPTION
1	10243	LID
2	10244	DUMP VALVE ARM
3	01211	DUMP VALVE LEVER
4	03061	FELT WASHER, 5/8 X 1 X 1/8
5	03020	SEAL
6	03060	BUSHING, IGUS MFI-1012-06
7	03241	LID GASKET
8	03242	MANIFOLD GASKET
9	10401	FITTING, 6400-6-6
10	10364	FITTING, 4601-16-12
11	10247	SUMP SCREEN #20 EXT #12 INT O-RING
12	03293	O-RING, 3-920N90, -20 FITTINGS
13	05225	CLAMP, 1" ID HOSE, CTB-35 ST
14	10366	SUCTION HOSE
15	10526	FITTING, 6409-12 PLUG
16	04555	FITTING, 6801-4-4
17	03040-06	DECAL, "HYDRAULIC OIL ONLY"
18	05038	RUE RING COTTER #8
19	05069	WHIZ-LOCK 1/4 - 20 X 5/8
20	05125	HH CAP SCREW, 1/4-20 NC X 1-1/4 G5 ZINC
21	05096	NUT, NYLOCK, 1/4-20 NC ZINC
22	05081	WASHER, 1/4 SAE ZINC

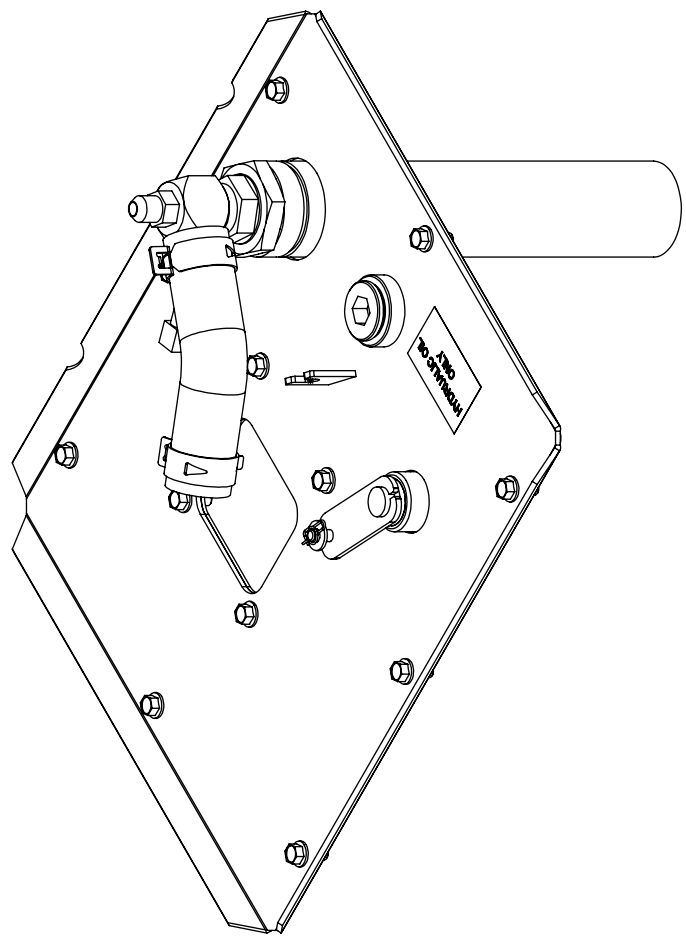
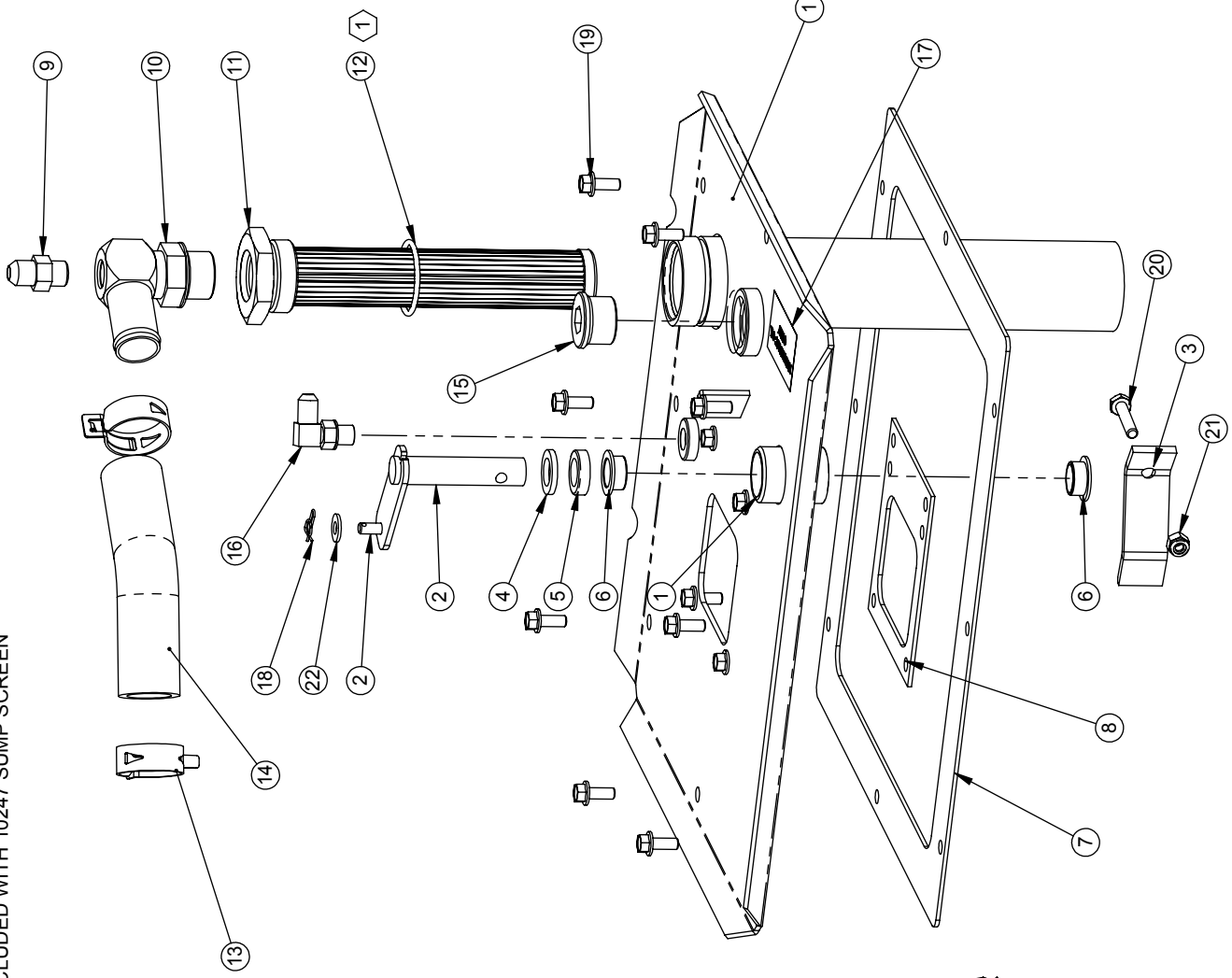

TITLE: LID ASSEMBLY

PRODUCT LINE: TRENCHER 912  
 SCALE: 1:4  
 SHEET 1 OF 1

**BARRETO**

DWG# 00267

DATE: 3/11/04

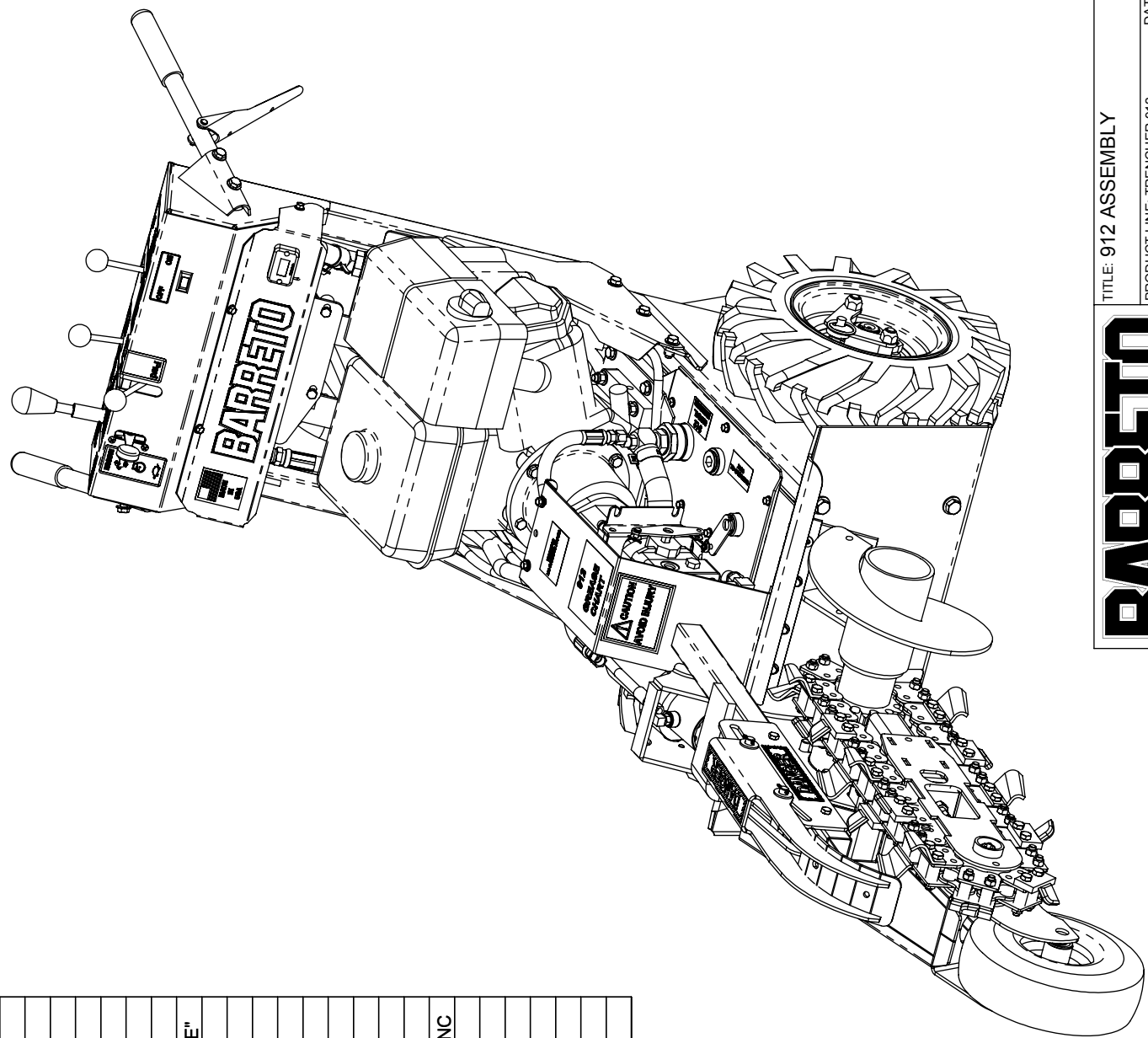

ITEM NO.	QTY.	PART NO.	DESCRIPTION
1	1	00247	BODY ASSEMBLY
2	1	00260	CONTROL ASSEMBLY
3	1	00261	ENGINE & PUMP ASSEMBLY
4	1	00262	FRONT END
5	1	10365	VENT HOSE ASSEMBLY
6	1	10544	PUMP COVER
7	1	03341-04	DECAL, "CAUTION - TO AVOID INJURY"
8	1	04440-09	DECAL, GREASE CHART
9	1	03341-24	DECAL, "WARNING - NO PARKING BRAKE"
10	1	10369	HOSE, PUMP OUTPUT
11	1	10372	HOSE, HYDROSTAT, RIGHT
12	1	10373	HOSE, HYDROSTAT, LEFT
13	1	10412	HOSE, CHAIN MOTOR, TOP
14	1	10413	HOSE, CHAIN MOTOR, BOTTOM
15	1	10414	HOSE, HYDROSTAT SUCTION
16	1	10415	HOSE, HYDROSTAT RETURN
17	1	10550	CYLINDER HOSE, TOP / PISTON
18	1	10551	CYLINDER HOSE, BOTTOM / ROD
19	4	05323	HH CAP SCREW, 1/2-13 NC X 1-1/4 G5 ZINC
20	4	05102	WASHER, 1/2 SAE ZINC HARDENED
21	6	05059	HH CAP SCREW, 3/8-16 NC X 1 G5 ZINC
22	6	05101	WASHER, 3/8 SAE ZINC
23	6	05073	NUT, NYLOCK, 3/8-16 NC ZINC
24	4	05049	WHIZ-LOCK 1/4 - 20 X 3/4
25	8	05081	WASHER, 1/4 SAE ZINC
26	4	05096	NUT, NYLOCK, 1/4-20 NC ZINC

TITLE: 912 ASSEMBLY

PRODUCT LINE: TRENCHER 912

DATE: 8/26/04

SCALE: 1:9

DWG# 00269

SHEET 1 OF 2

# BARRETO

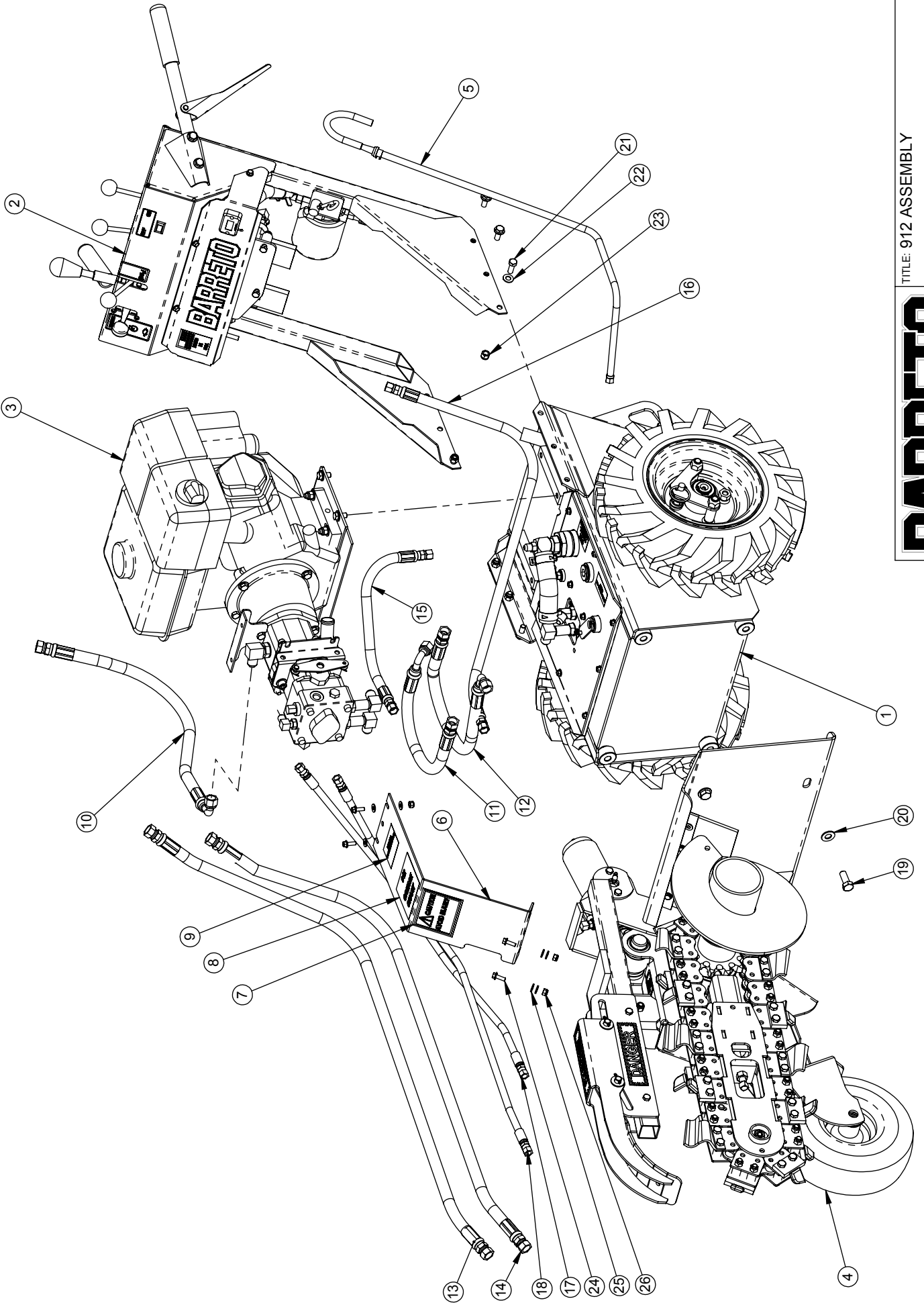

TITLE: 912 ASSEMBLY

PRODUCT LINE: TRENCHER 912

SCALE: 1:10

DATE: 8/26/04

DWG# 00269

SHEET 2 OF 2

# BARRETO

REVISED 10/13/13

KEY SUPPLIED WITH MOTOR  
1/4 X 1" WOODRUFF PN 05013

REF QTY.	PART NO.	DESCRIPTION
1	10228	TRANSMISSION PLATE, MOTOR SIDE
2	10229	TRANSMISSION PLATE, WHEEL SIDE
3	10183	BEARING HOUSING, AXLE
4	10230	AXLE, RIGHT
5	10063	GEAR, WHEEL DRIVE, 36T X 1-1/4
6	02075	GEAR, WHEEL DRIVE MOTOR
7	10235	BEARING HOUSING, AXLE
8	10219	GEARBOX SPACER
9	04502-F	WHEEL DRIVE MOTOR
10	05015	KEY, 5/16 X 5/16 X 1-1/4
11	03280	BALL BEARING, SKF 6206
12	05214	SNAP RING, 1-1/4" EXTERNAL, SH-125
13	05034	SNAP RING, 1-3/16 EXT, SH-118
14	05044	GREASE ZERK, 1/4-28 UNF
15	05323	HH CAP SCREW, 1/2-13 NC X 1-1/4 G5 ZINC
16	05067	HH CAP SCREW, 1/2-13 NC X 1 G5 ZINC
17	05102	WASHER, 1/2 SAE ZINC HARDENED
18	05140	WHIZ-LOCK 5/16 - 18 X 3/4
19	05546	WASHER, 5/16 X 1 1/2 ZN
20	05237	HH CAP SCREW, 1/4-20 NC X 1 G5 ZINC

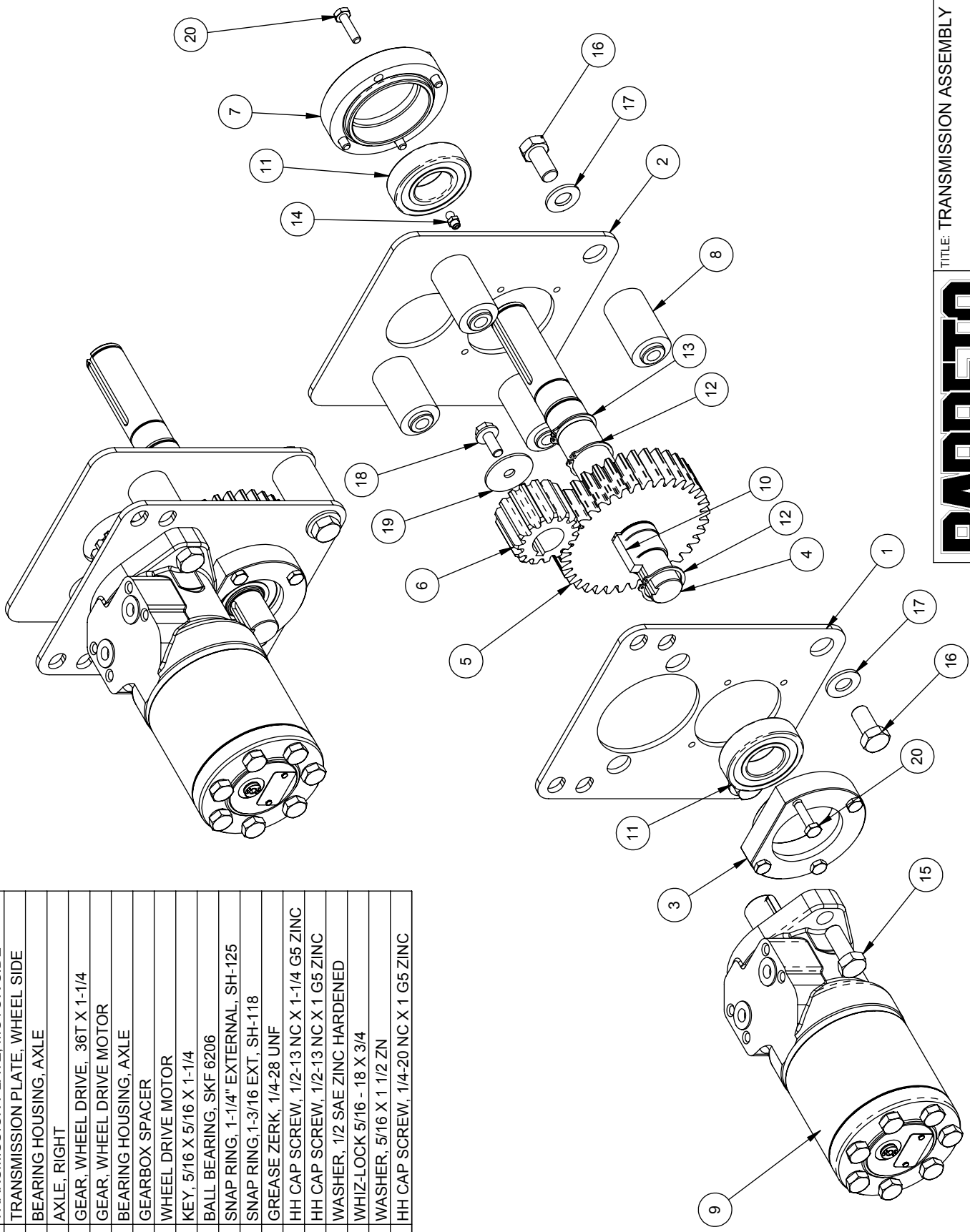

# BARRETO

TITLE: TRANSMISSION ASSEMBLY

PRODUCT LINE: TRENCHER 912 DATE: 3/10/04

SCALE: 1:4 DWG# 00268 SHEET 1 OF 1

UPDATED 10/11/16

REF QTY.	PART NO.	DESCRIPTION
1	10497	CYLINDER, 2.5 X 5.75" STROKE
2	10499	CYLINDER ROD, 5.75" STROKE
3	02612	PISTON
4	02613	CYLINDER END
5	02616	CYLINDER ROD END
6	10498	BUSHING, IGUS MFI-2024-12
7	05211	SNAP RING, HO-256, 2-9/16 INTERNAL ZINC
8	03255	WIPER, 1 X 1-1/2 X 5/16 J-1000
9	03259	SEAL, 1x1/8x1/8 ROD
10	03234	O-RING, 2-228, 2-1/2 OD X 1/8 SECTION
11	03232	O-RING, 2-014, 5/8 OD X 1/16 SECTION
12	03237	BACK-UP RING, 8-330N90 PARBAK
13	03236	O-RING, 2-330, 2-1/2 OD X 3/16 SECTION
14	04555	FITTING, 6801-4-4
15	04560	FITTING, 6400-4-4
16	05044	GREASE ZERK, 1/4-28 UNF
17	05251	HH CAP SCREW, 1/2-20 NF X 2 G5 ZINC
18	05102	WASHER, 1/2 SAE ZINC HARDENED
19	05076	NUT, GRIPCO, 1/2-20 NF G5 ZINC
20	05046	NUT, GRIPCO, 1/2-13 NC G5 ZINC

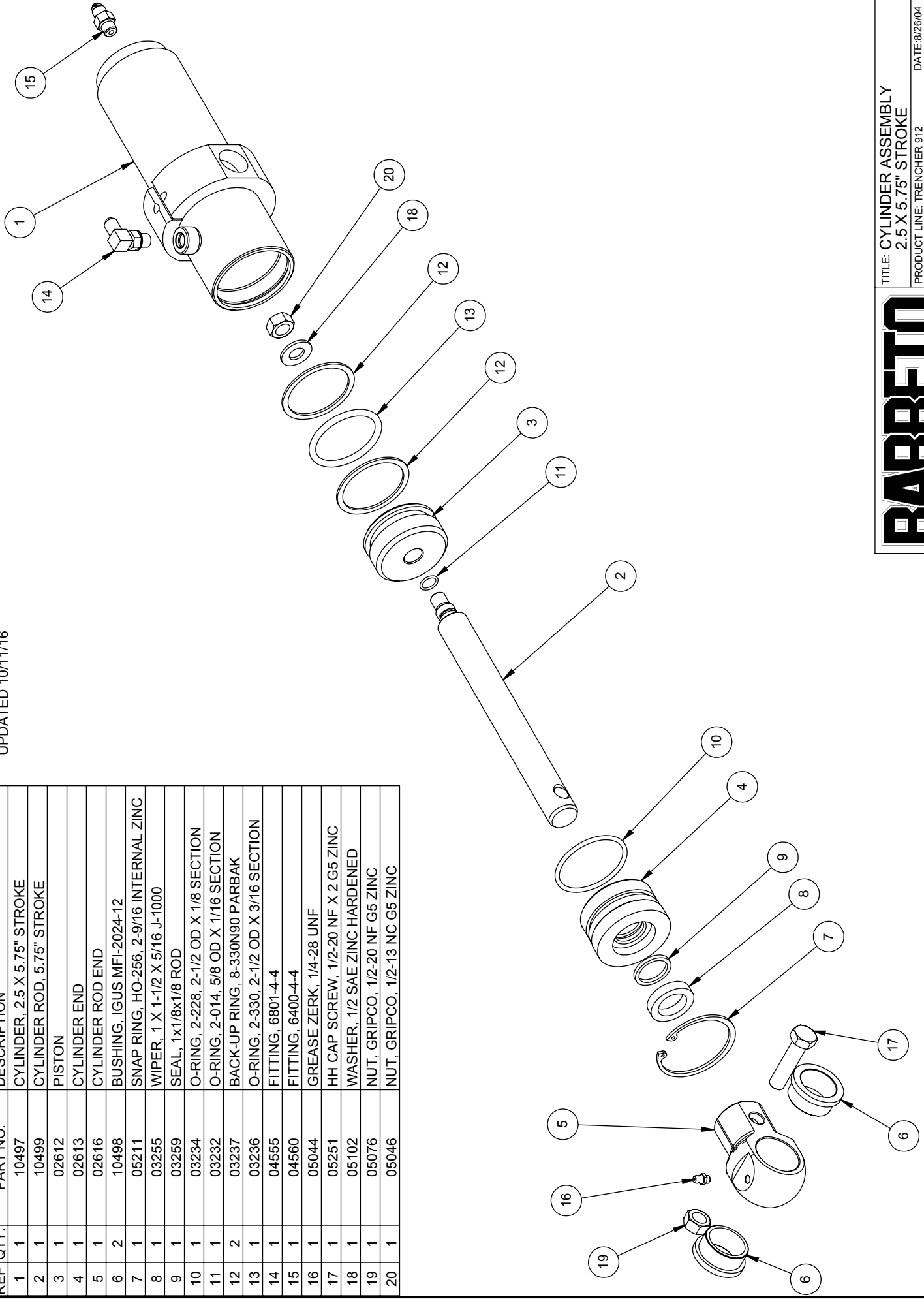

# BARRETO

TITLE: CYLINDER ASSEMBLY  
 2.5 X 5.75" STROKE  
 PRODUCT LINE: TRENCHER 912  
 SCALE: 1:4  
 SHEET 1 OF 1  
 DATE: 8/26/04  
 DWG# 00271

RELEASE DATE	2/06
REVISED DATE	10/11/16
REVISION #	1

ITEM NO.	QTY.	PART NO.	DESCRIPTION
1	1	10520	SPEED LEVER MOUNT
2	1	10547	SPEED LEVER ROLLER
3	1	10524	SPEED LEVER
4	1	10521	SPEED LEVER PIVOT
5	1	11031	SPEED LEVER SPACER, .62
6	1	10523	SPEED LINK
7	1	10519	SPEED CABLE ARM
8	1	10525	SPACER, .31
9	1	03508	SPEED KNOB
10	3	05506	SNAP RING, 1/2" EXTERNAL, SH-50
11	1	03514	CABLE, 40"
12	1	03045	CABLE, 47"
13	1	03029-02	CLEVIS PIN, 1/4 X 1-5/8 ZINC
14	1	05243	HH CAP SCREW, 1/4-28 NF X 1-3/4 G5 ZINC
15	2	03029-04	BUSHING, MICRO PLASTICS 12SWS1048
16	1	05266	NUT, GRIPCO, 1/4-28 NF G5 ZINC
17	1	05283	NUT, GRIPCO, 3/8-24 NF G8 ZINC
18	2	05101	WASHER, 3/8 SAE ZINC
19	2	10509	BUSHING, IGUS RFI-0608-06
20	2	10113	THRUST WASHER, .518 X .873 X .030
21	2	12078	BUSHING, IGUS RFI-0810-06
22	1	05235	SH CAP SCREW, 1/4-28 NF X 3/4 PLAIN
23	5	05081	WASHER, 1/4 SAE ZINC
24	4	05038	RUE RING COTTER #8

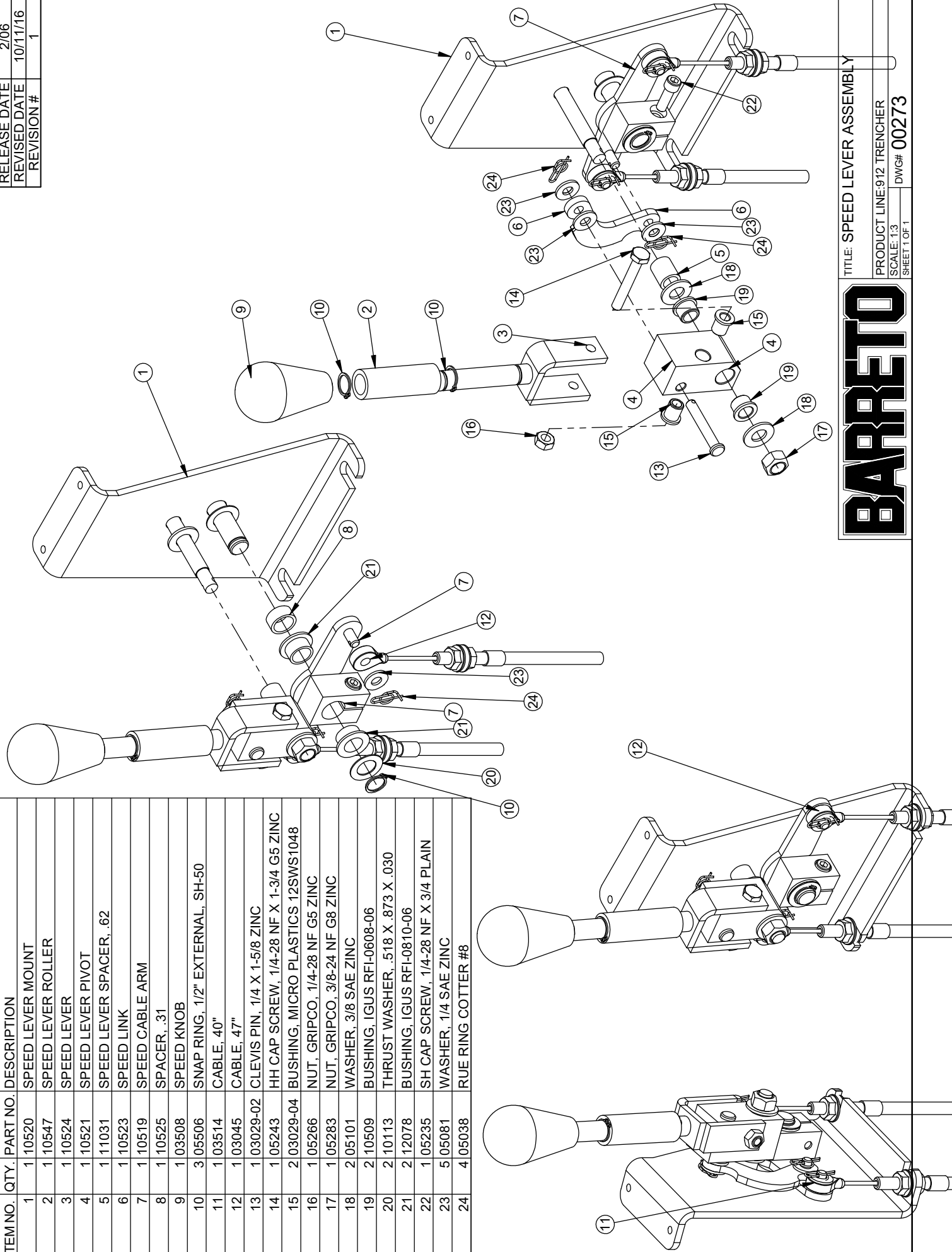

# BARRETO

TITLE:	SPEED LEVER ASSEMBLY
PRODUCT LINE:	912 TRENCHER
SCALE:	1:3
SHEET:	1 OF 1
DWG#:	00273

REF	QTY.	PART NO.	DESCRIPTION
1	1	02269	WHEEL HUB
2	1	01252	FREE WHEEL HUB
3	2	03168	BUSHING, SLEEVE, NYLON, IGUS MSI+2832-12
4	1	05610	SNAP RING, SH-175, 1-3/4" EXTERNAL
5	1	05066	KNURLED STUD, 1/2-20 UNF X 1, G8
6	2	05166	KNURLED STUD, 1/2-20 UNF X 3, G8

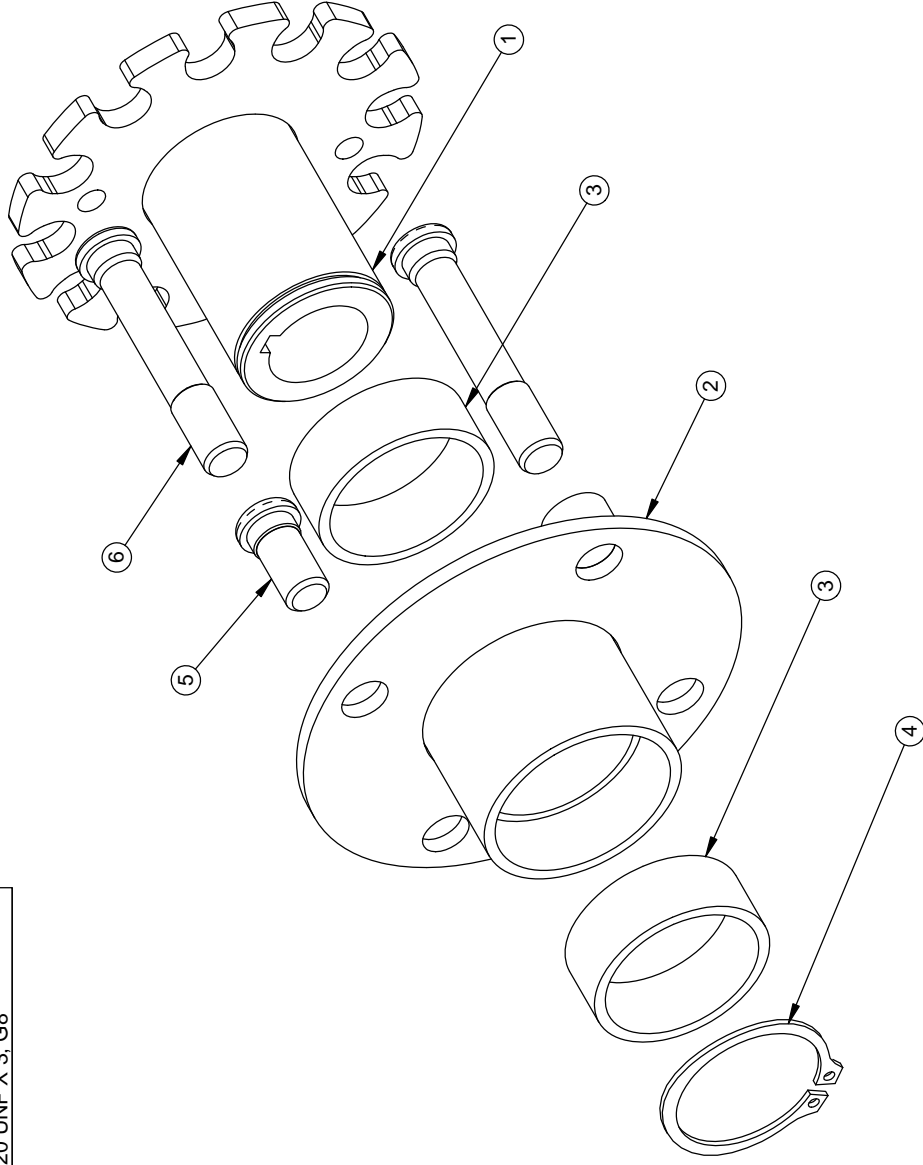

NOTES:

- 1. USAGE: 2 PER 00231 R3, 00256 R1, & 10388.
- 1 OF 00231 R3 PER 1318.
- 1 OF 00256 R1 PER 912, 916 & 918.
- 1 OF 10388 PER 1320 & 1620.

**BARRETO**

TITLE: WHEEL HUB ASSY, 1-1/8" BORE

PRODUCT LINE: COMMON DATE: 8/6/07

SCALE: 1:2 DWG# 02269-HUB

SHEET 1 OF 1



66498 HWY 203  
LA GRANDE, OR 97850  
(541) 963-7348

DATE	REV/DESCRIPTION	DWN/APP
08/07	0 INITIAL RELEASE	MZL
02/27/09	1 CHANGED BENDS FOR MORE HOSE CLEARANCE	MZL

MASS: 10.751 POUNDS

NOTES:

FINISH: PAINT BLACK

REF.	QTY.	PART NO.	DESCRIPTION
1	1	A1560-1L	SIDE PLATE, LIFT EYE
2	1	A1560-1R	SIDE PLATE
3	1	A1560-2	EYE

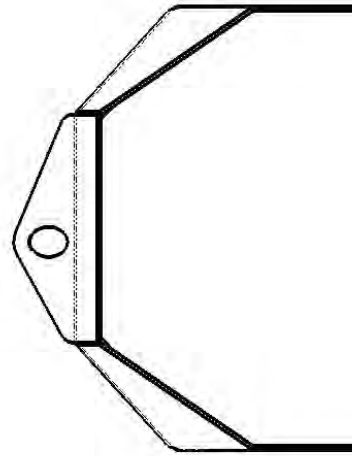
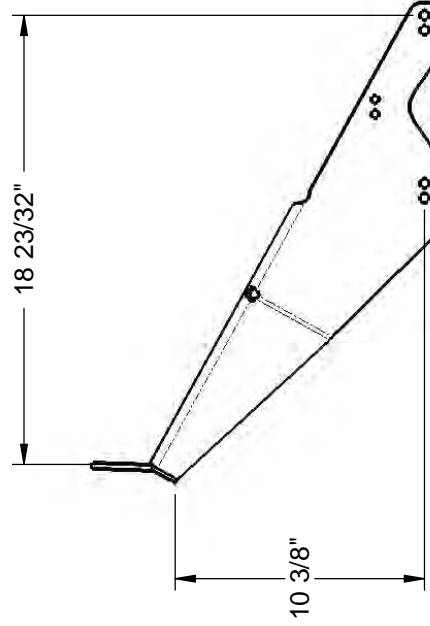
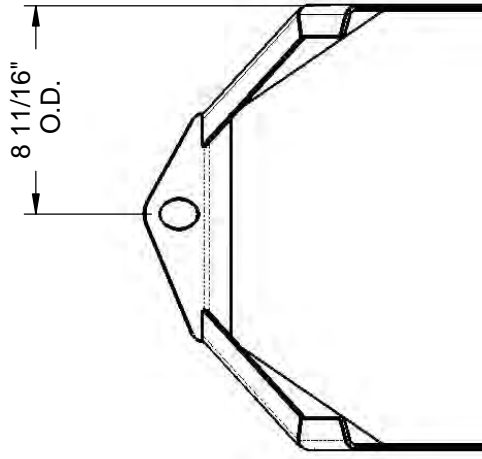
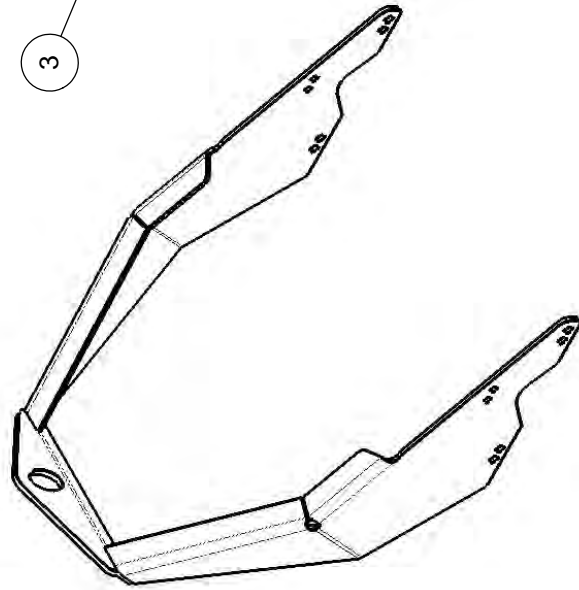
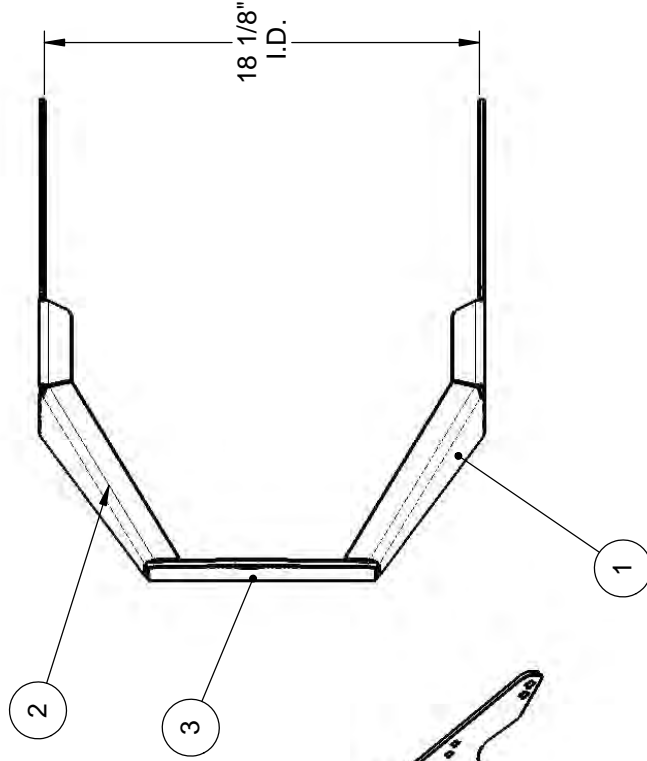

TOLERANCES UNLESS OTHERWISE SPECIFIED  
 FRACTIONS: DECIMALS: ANGLES:  
 >=1/16 = ±1/16 .X = ±.1 °2°  
 1/32 = ±1/32 .XX = ±.03  
 1/64 = ±1/64 .XXX = ±.005

TITLE: LIFT EYE, 912  
 PRODUCT LINE: 912 TRENCHER  
 SCALE: 1:8 DWG# A1560  
 SHEET 1 OF 1

# 912 Trencher decals

P/N 03040-01



P/N 03040-02



P/N 03040-04



P/N 03040-06



P/N 03040-07



P/N 03040-57



P/N 03341-05

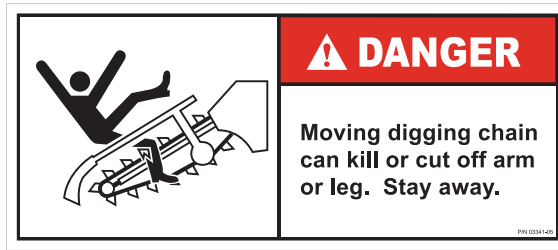

P/N 03341-07



P/N 03341-12



P/N 03341-24



P/N 04430-05



P/N 04440-02



P/N 04440-03



P/N 04440-04

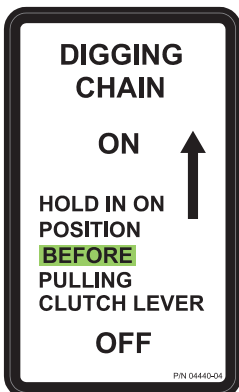

P/N 04440-05

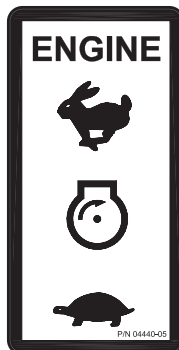

P/N 04440-06

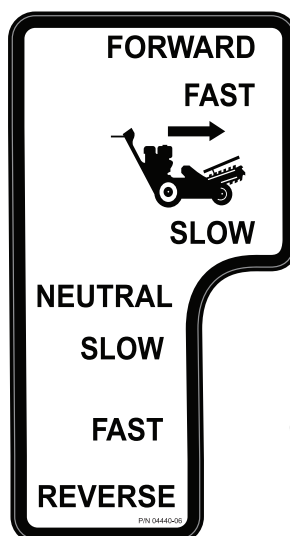

P/N 04440-07

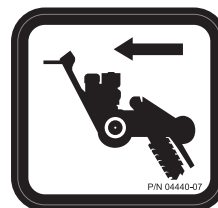

P/N 04440-09

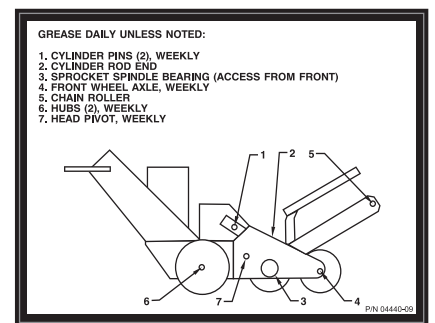

ORDER P/N K3341-912 FOR COMPLETE SET



## 712/912 TRENCHER CHAIN TYPES / DESCRIPTIONS

### **STANDARD CUP CHAIN** (AKA Skip Tooth)

This chain has a cup tooth on every other link.

#### **Where to use it**

This chain is most effective in loamy soil - soil that is packable into clods. It is also more effective in clay or "gumbo" soil that is sticky and clings to the chain. The space between the cups allows the soil to let go instead of running around with the chain as a slurry which prevents effective digging.



### **DOUBLE CUP CHAIN**

This chain has a cup tooth on every link.

#### **Where to use it**

This chain is best for sand and dry, loose soil that has a tendency to fall back into the trench. The extra cups provide for better clean-out.



### **COMBO/SHARK CHAIN**

This chain has an alternating pattern of cup and Shark teeth.

#### **Where to use it.**

Use this chain in pretty much the same conditions as the standard combo chain. Although not as aggressive, the Shark teeth last longer and do not fall off. This is our most popular chain.



### **SHARK CHAIN**

The teeth on this chain are all Shark teeth that are welded onto the chain. Replacement teeth are not available for this chain.

#### **Where to use it.**

This chain can be used in the most adverse soils. It is good in rocky soil, "cliché", limestone, hard-pan and any other hard to dig soils. It does not clean out well in sandy or dry, loose, loamy soil. This is not the fastest but it is the most durable chain available. It is not uncommon for the teeth to outlast the chain rollers. When the rollers wear out, the complete chain must be replaced.



### **BOLT-ON SHARK CHAIN**

This chain utilizes a standard chain blank and has Shark teeth that are bolted to the chain blank.

#### **Where to use it.**

This chain is good in all the conditions described for the Shark chain. The advantage is the teeth can be removed when the chain wears out and can be used on a new blank. It is not uncommon for the teeth to last through two chains.



**NOTE: The 712 trencher chains are available in 12" & 18" lengths and 4" & 5" widths. The 912 chains are available in 12", 18", & 24" lengths and 4" & 6" widths.**